

Cahier technique no. 154

LV circuit-breaker breaking techniques

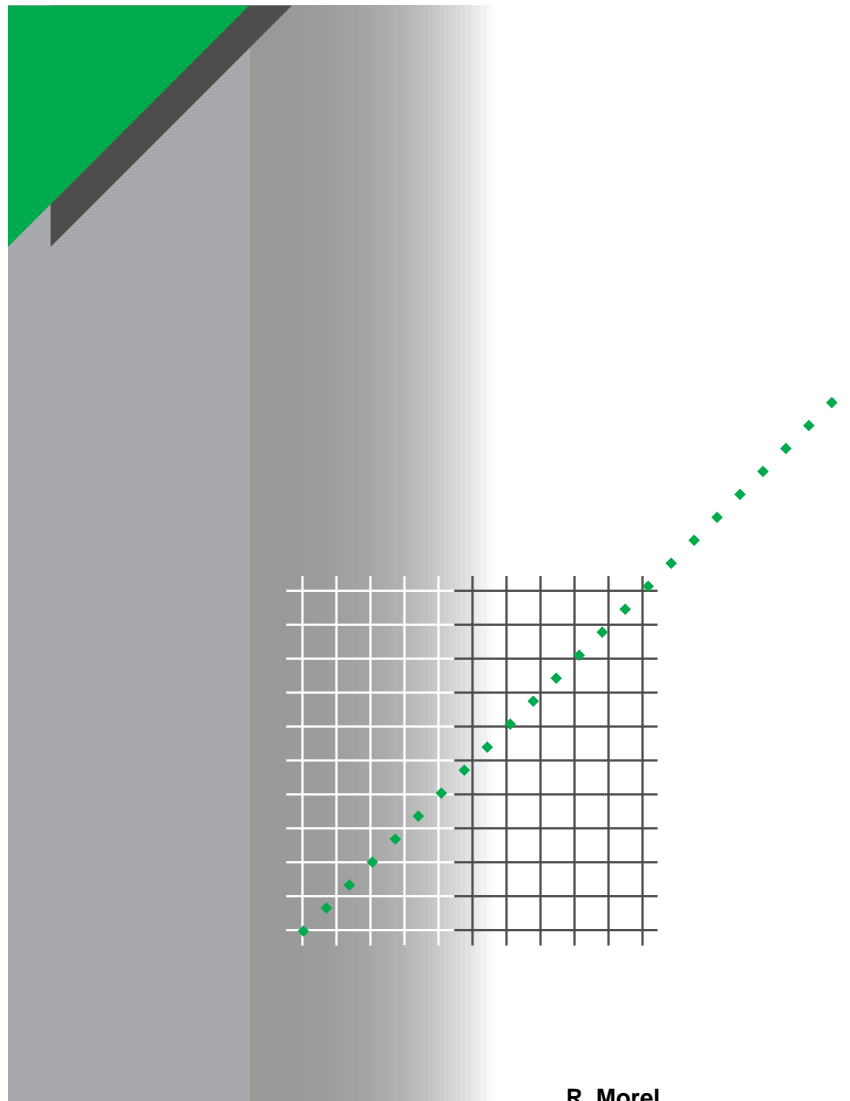

Merlin Gerin

Modicon

Square D

Telemecanique

R. Morel

"Cahiers Techniques" is a collection of documents intended for engineers and technicians, people in the industry who are looking for more in-depth information in order to complement that given in product catalogues.

Furthermore, these "Cahiers Techniques" are often considered as helpful "tools" for training courses.

They provide knowledge on new technical and technological developments in the electrotechnical field and electronics. They also provide better understanding of various phenomena observed in electrical installations, systems and equipments.

Each "Cahier Technique" provides an in-depth study of a precise subject in the fields of electrical networks, protection devices, monitoring and control and industrial automation systems.

The latest publications can be downloaded from the Schneider Electric internet web site.

Code: <http://www.schneider-electric.com>

Section: **Experts' place**

Please contact your Schneider Electric representative if you want either a "Cahier Technique" or the list of available titles.

The "Cahiers Techniques" collection is part of the Schneider Electric's "Collection technique".

Foreword

The author disclaims all responsibility subsequent to incorrect use of information or diagrams reproduced in this document, and cannot be held responsible for any errors or oversights, or for the consequences of using information and diagrams contained in this document.

Reproduction of all or part of a "Cahier Technique" is authorised with the prior consent of the Scientific and Technical Division. The statement "Extracted from Schneider Electric "Cahier Technique" no." (please specify) is compulsory.

no. 154

LV circuit-breaker breaking techniques

Robert Morel

«.... to my work friends and colleagues.»



Graduated with an engineering degree from ENSMM in Besançon and joined Merlin Gerin in 1971.

Specialised in designing low-voltage switchgear and participated in designing the Sellim system.

In 1980, took over development of Compact Circuit-breakers and Interpact switches.

In 1985, became manager of the Low-Voltage Current Interruption design office in the Low-Voltage Power Components division.

Lexicon

α : closing voltage angle.

category (of a circuit-breaker): defined by standard IEC 947.2.

A = circuit-breaker not delayed on opening in short-circuit conditions;

B = circuit-breaker delayed on opening in short-circuit < I_{cw} conditions.

E: DC rated voltage, AC peak voltage.

φ : voltage/current phase angle.

i, (**i_0**): current at an instant t , (at an instant t_0).

i_a : arcing current at an instant t .

\hat{i}_c : broken peak current.

I_{cc}: short-circuit current.

I_{cs}: rated service breaking capacity (expressed in kA or in % of I_{cu}).

I_{cu}: rated short-circuit ultimate breaking capacity.

I_{cw}: rated acceptable short current.

I_n: rated current in steady state, Ar.m.s.

I_p: prospective current.

I_s: overload current.

r: generator impedance.

R, L, C: total components of broken circuit.

rating (of a circuit-breaker): rated current value of the circuit-breaker, defined by the maximum setting of the trip unit (electronic or thermal overload protection).

size (of a circuit-breaker): the highest rating accepted by a circuit-breaker case. It is the rated current of the device.

t, (t_0): time (initial instant).

t_a : arcing time.

τ : time constant ($\tau = L / R$).

u: voltage at an instant t .

u_a : arcing voltage at an instant t .

U_a : stabilised arcing voltage.

U_{AC} : Anode-Cathode voltage of each elementary arc.

U_{d+} , U_{d-} : regeneration characteristics.

U_n : rated voltage in AC, V r.m.s.

U_r : recovery voltage.

W_a : arcing energy.

W_{L0} : initial inductive energy for $i = i_0$.

ω : AC pulsation
($\omega = 2\pi f = 2\pi/T$).

LV circuit-breaker breaking techniques

This Cahier Technique aims to:

- define the currents to break in LV installations;
- explain a phenomenon which occurs whenever a circuit is opened: **the electric arc**;
- theoretically analyse the breaking of various currents by the arc placed in the extinguishing condition;
- describe breaking devices and in particular circuit-breakers from a technological standpoint.

Contents

1 Introduction	1.1 Definition of currents to break	p. 4
2 The electric arc	2.1 Its formation conditions	p. 6
	2.2 Its physical properties	p. 6
	2.3 Its electrical properties	p. 6
	2.4 Its extinguishing conditions	p. 7
3 Using the arc to break the current		p. 9
4 Breaking steady-state currents	4.1 In DC supply	p. 10
	4.2 In AC single-phase supply	p. 11
	4.3 In AC three-phase supply	p. 12
5 Breaking prospective currents (with limitation)	5.1 Definitions	p. 13
	5.2 Breaking with limitation	p. 16
	5.3 Under DC voltage	p. 16
	5.4 Under single-phase AC voltage	p. 16
	5.5 Under three-phase AC voltage	p. 17
	5.6 The breaking parameters	p. 17
	5.7 Fuse breaking technique	p. 18
6 The low voltage circuit-breaker	6.1 Its functions	p. 19
	6.2 Its technologies	p. 20
	6.3 Its performances	p. 24
7 Conclusion		p. 27
Bibliography		p. 27

1 Introduction

The energy sources for electrical installations are AC generators and transformers. All these generators, however perfect, have an internal impedance which has two major effects (see **fig. 1**).

- in normal operating conditions, this impedance causes voltage to drop from no-load condition to bring it to U_n when the generator delivers I_n ;
- when a short-circuit occurs, this impedance limits the current to a value, given in multiples of I_n .

To take the example of transformers, their short-circuit voltage U_{cc} (as a %) corresponds to the

upper limit of their relative voltage drop under rated current, I_n .

For example, an I_{cc} of $I_n/5\% = 20 I_n$ is obtained for a short-circuit voltage of 5%, i.e. a current of 29 kA for a 1000 kVA/400 V transformer. It is not hard to imagine the damage such a current could cause in an installation (temperature rises and electrodynamic forces are proportional to the current square!).

Thus, even if all precautions are taken to make such an occurrence unlikely, protective devices are still needed to break the short-circuit currents.

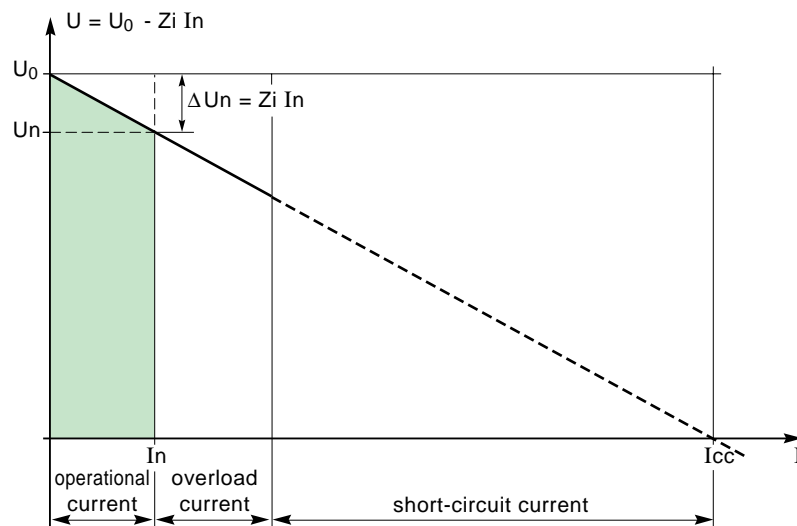

Fig. 1: incidence of internal impedance Z_i of energy sources on voltage delivered and their maximum short-circuit currents.

1.1 Definition of currents to break

Knowing the value of the current to break is not enough to design a suitable breaking device !

Current breaking is dependent on a number of parameters relating to generators (a.c. generators or transformers), lines and loads:

- an electric circuit is always inductive, and thus the very fluctuations in the current to break,

generate, as soon as the circuit is opened, negative current feedback which help maintain the current. The value of this back-electromotive voltage of the $L \frac{di}{dt}$ type may be high whatever the value of current i until this current is cancelled;

- the resistive value of the circuit to break is of assistance in breaking as long as the current is

high, but ceases to be of any help when current tends to zero, since the ohmic drop is then negligible;

- the capacities between live conductors, whether distributed ("stray" capacities of generators and cables) or additional (capacitor bank in reactive energy compensation or filter), alter breaking conditions;
- the frequency of the current to break, since in theory it is easier to break a.c. currents with periodic zeros than d.c. currents;
- finally, the voltage delivered by the generator. Once the current has been cancelled, the breaking device must dielectrically withstand the mains voltage still present.

In practice, there are three types of currents to break:

1. Short-circuit current

In a given point of an installation, this current is not systematically equal to "20 In" of the generator:

- it depends on the generator characteristics, 3% < U_{cc} < 7% for example;
- it may be smaller:
 - according to the fullness of the fault
 - according to the length and cross-section of the upstream lines;
- it may be greater if a number of generators are parallel-connected.

2. Overload current

The current may overshoot rated value and become unacceptable after a certain time:

- during the transient period of load startup or operation;
- if the sum of the powers of the loads in operation exceeds the designer's estimates for all or part of the installation.

3. Rated current (or lower)

Since a circuit-breaker's function is to break high short-circuit currents and overloads, it can also provide circuit and load control.

2 The electric arc

The electric arc is no invention, but appeared to the first physicist who tried to break a circuit through which a current flowed.

Circuits, always inductive, supply electrons with sufficient energy to cross the distance in the conductor separation zone.

The gas present, normally air, is ionised by these "pioneer" electrons and the resulting plasma will then facilitate current flow.

Breaking thus seems somewhat compromised... unless a better understanding of this phenomenon were to reveal remarkable and even irreplaceable properties. Luckily this is the case !

2.1 Its formation conditions

The arc appears in gaseous atmospheres:

- by dielectric breakdown between two electrodes:
- beyond an electric field value E/d , dependent on electrode shape and on gas type and density (d = distance between electrodes (see **fig. 2**) ;
- further to moving over insulating materials in the ambient gas.
- as soon as an electric circuit opens through which current flows, even if the circuit is purely resistive, a certain opening distance is necessary to prevent dielectric breakdown.



Fig. 2 : electric arc and influence of field E/d value.

Moreover, any attempt to reduce current rapidly creates a high $L di/dt$ thus favouring breakdown at any current level.

2.2 Its physical properties (see **fig. 3a**)

As soon as two contacts separate, one of them (cathode) transmits electrons and the other one (anode) receives them. Since electronic emission is by its very nature energy generating, the cathode will be hot. With the arc foot thus becoming thermoemissive, the electrons are mostly emitted at the hot spot, resulting in arc stagnation which can give rise to metallic vapours. These vapours and the ambient gas will then be ionised, hence:

- more free electrons ;
- the creation of positive ions which drop back on the cathode, thus maintaining its high temperature;
- the creation of negative ions which bombard the anode causing temperature to rise.

All this occurs in a high temperature plasma column, from 4 000 to 20 000 K according to column current and confinement.

2.3 Its electrical properties (see **fig. 3b**)

- its most striking property is the appearance of an arcing voltage, which has:
 - a fixed part, $U_{AC} \approx 20$ to 40 V which appears on the slightest separation of the contacts (depending on the materials used),
 - a variable part, $U_L = 50$ to 100 V/cm, when the arc is stabilized in elongation in pressure-temperature balanced conditions.

i.e. a total value $U_a = U_{AC} + U_L$.

Note that:

- the sign of U_a changes at the same time as the arcing current sign,
- the arcing current value does not have any real effect on arcing voltage. This is because the arc "works" with a virtually constant current density ($j=i/s$), (the anode and cathode spot cross-

a: composition of the arc column

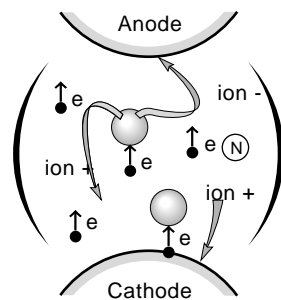

b1: arc voltage U_{AC}

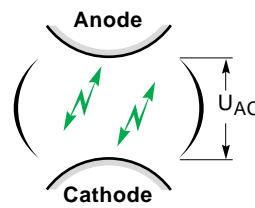

b2: arc voltage U_L

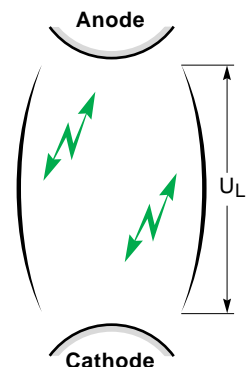

$$U_a = U_{AC} + U_L$$

Fig. 3: the electric arc, its physical phenomenon (a) and its characteristic or arcing voltage U_a (b).

sections and the arc column cross-section are proportional to the current, hence by analogy with a resistance:

$$U = R i = \rho \frac{l}{S} = \rho \cdot l \cdot j = \text{"constant"};$$

■ an arcing energy is produced;

$$W_a = \int u_a i_a dt$$

■ if the arc is placed in a magnetic field, it is subjected to Laplace's law forces,

$F = B i l \sin \alpha$ which causes it to bend if \vec{E} is perpendicular to \vec{i} , and then to move transversely.

2.4 Its extinguishing conditions

The arc is extinguished when the arcing current value becomes and **remains** zero.

Thermal aspect

When the arcing current is low or drops, below 10 A for example, the heat energy exchanges may exceed internal arcing energy, causing the arc to «die» of cold. This results in an increase in arcing voltage (see fig. 4a).

During this voltage rise, the arc may even suddenly be extinguished if it is "short-circuited" by stray capacities. This is the case when arcing voltage becomes and remains greater than the charging voltage of the distributed capacities (see fig. 4b). This phenomenon is known as "pinching off".

However there are exceptions:

■ if the arcing current stabilises against an insulating wall, its heat exchange area decreases, and the insulating material components, locally very hot, may promote arc conduction and holding.

■ if the arcing current is high, the arc column is extremely exothermal and only the joint evolutions in arcing voltage and mains voltage can reduce and finally cancel this current.

a: extinction of the arc

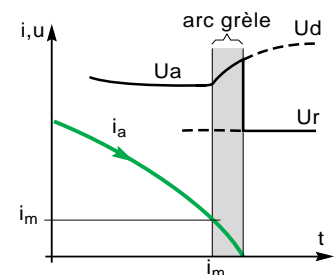

b: stray capacitors "short-circuit" the arc

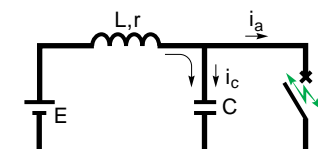

Fig. 4 : extinguishing of an electric arc by "pinching off".

Dielectric aspect

The arcing current is not extinguished merely by reaching zero. In addition, the atmosphere ionised up to that point must be dielectrically regenerated in order to "withstand" the mains voltage still present !

These regeneration phenomena of recombination of + or - ions and electrons are fortunately very fast ! Thus, in practice, for the arcing current to remain zero, mains voltage must be less than the regeneration characteristic (U_d). If arcing voltage becomes and remains greater than mains voltage (in absolute value for ac voltage), regeneration will begin as the current zero approaches. The number of plasma electric charges adjusts itself to the strict minimum and becomes zero at the same time as the current.

However the arc and the stray capacities have the same voltage until the arcing current is extinguished. Once this happens, this voltage rejoins mains voltage through free oscillation between these distributed capacities and circuit constants L and R (see **fig. 5**). This voltage "connection" is known as the Transient Recovery Voltage (TRV).

Low capacities mean these oscillations have a very high frequency and are extremely damped.

These conditions are present:

- in dc voltage: (see **fig. 6a**);
The arcing voltage, U_a , is greater than mains voltage, U_r , when the current is cancelled, and the regeneration characteristic, U_d , remains greater than U_r with TRV.

- in ac voltage:
- when the instantaneous mains voltage value still has the same sign as arcing voltage at the

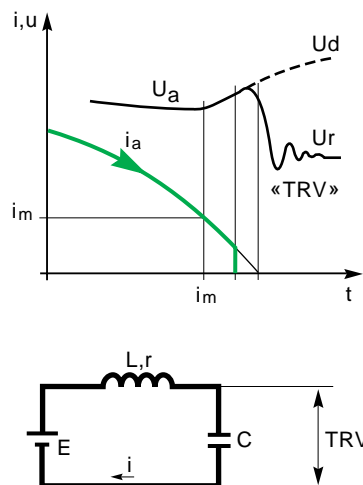

Fig. 5: the transient recovery voltage, TRV.

time of current zero (see **fig. 6b**). Final breaking will occur when subsequent change in mains voltage ceases to cross the regeneration characteristics in either positive or negative values.

- when the instantaneous mains voltage value has the opposite sign to arcing voltage but has an absolute lower value (see **fig. 6c**). The arc is permanently extinguished if the TRV does not exceed the regeneration characteristic.

Otherwise, when the TRV breaks the regeneration "curve", a postarcing current of the electroluminescent type may appear. In this case:

- if the postarcing current is still of the small type, extinguishing conditions are still present;
- if the postarcing current exceeds a critical value under an equally critical voltage, the arcing current will be recovered and another "zero" will be required to break.

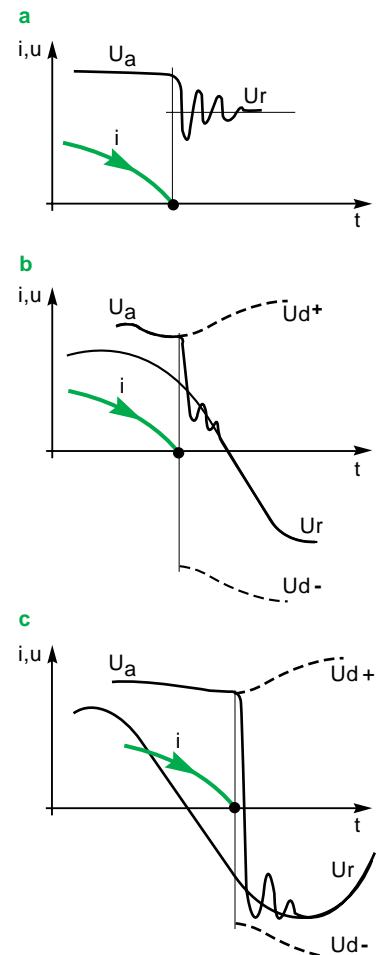

Fig. 6: arc in extinguishing condition.

a- in d.c. voltage

b- in a.c. voltage with U_r of same sign as U_a at the time of zero current,

c- in a.c. voltage with U_r of opposite sign to U_a .

3 Using the arc to break the current

The current established on closing can be calculated by the extended Ohm's law:
 $e - R i - L \frac{di}{dt} = 0$.

Following a transient closing state, the current becomes stable or in steady state $I = \frac{e}{R}$.

On the basis of such a law, the current can only be cancelled permanently if the voltage "e" becomes zero or if R becomes infinite.

In preference to these two extremes which would present too many operational restrictions, an arc was introduced in the circuit for use of its U_a voltage properties and extinguishing conditions. As soon as the circuit opens, the equation becomes:

$$e - R i - L \frac{di}{dt} - u_a = 0.$$

The current will thus be forced to zero or will pass through zero, and the arc extinguishing conditions will break the current.

The examination of the two different cases below provides a progressive approach to the breaking theory:

- the U_a arcing voltage was introduced in the circuit when the current was in steady state (see chapter 4);
- the U_a arcing voltage was introduced in the circuit before the current reached the stabilized value of the prospective current (see chapter 5).

4 Breaking steady-state currents

Steady-state currents are rated currents, overload currents and short-circuit currents which have reached a stable value on circuit opening.

Circuit opening may be:

- voluntary, controlled by the user, completely separate from current value;

- "reflex", by the action of a device affected by current value and directly or indirectly controlling circuit opening.

For simplicity's sake, breaking conditions are examined :

- in d.c. voltage;
- then in a.c. voltage.

4.1 In DC supply

$u = E$

before opening: $i_0 = E/R$

after opening: $E - R i - L di/dt - u_a = 0$

When the contacts open, u_a moves towards a maximum value U_a (see fig. 7).

Ohm's extended law shows that current can only be forced to "0" if u_a becomes greater than E.

Otherwise, it will move to

$i'_0 = (E - U_a)/R$, not zero.

For current breaking purposes, it is thus easier and sufficiently clear to consider this arcing voltage as a step function, $u_a = U_a$ for $t > t_0$,

($t_0 =$ instant when $u_a = E$).

The complete calculation then yields:

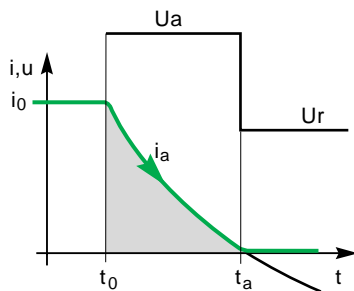
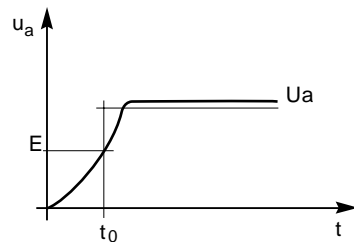
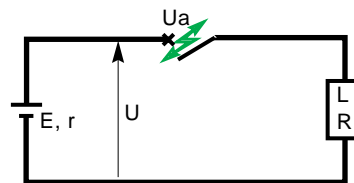

Fig. 7: breaking under dc voltage.

$$i_a = \frac{E}{R} - \frac{U_a}{R} \left(1 - e^{-\frac{t-t_0}{\tau}} \right) \text{ and } t_a = \tau \text{Log} \frac{U_a}{U_a - E}$$

remembering that breaking occurs as soon as the current passes through zero (a «negative» current due to dominance of U_a compared with U_r has no physical significance).

Calculation of the integral:

$$W_a = \int_{t_0}^{t_a} u_a i_a dt \text{ gives}$$

$$W_a = \left(\frac{1}{2} L i_0^2 \right) 2 \frac{U_a}{E} \left[1 + \left(1 - \frac{U_a}{E} \right) \text{Log} \frac{U_a}{U_a - E} \right]$$

It is easier to interpret this expression by writing: $W_{L0} = (1/2 L i_0^2)$ and observing the curves (W_a/W_{L0}), and

(t_a/τ) as a function of (U_a/E), (see fig. 8).

These curves show:

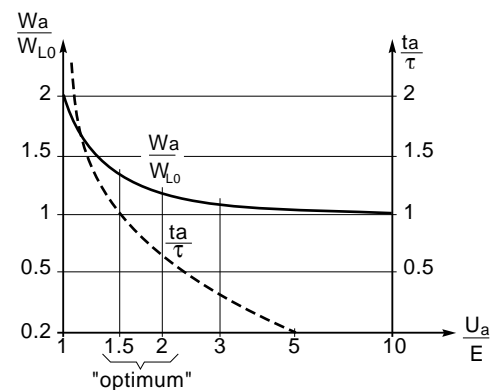

Fig. 8: curves W_a/W_{L0} and t_a/τ .

- if $U_a = E$ then $W_a/W_{L0} = 2$ only! But breaking time is infinite!
- if U_a is very big or even infinite then:
 $W_a/W_{L0} = 1$.
 Arcing energy is equal to initial inductive energy and breaking time is virtually zero: arcing power W_a/t_a is very high!
- that the "bend" of curve W_a/W_{L0} is a practical optimum and thus that the value :

$$1,5 < \frac{U_a}{E} < 2,5$$

is a good compromise; then
 $W_a \approx 1.2 W_{L0}$ and $t_a \approx \tau$.

The coefficient 1.2 (read on the bend) is very satisfactory due to its proximity to the "1" minimum, difficult to reach.

4.2 In AC single-phase supply

$$u = E \sin \omega t$$

$$i = I_0 \cos (\omega t + \varphi), \text{ with}$$

$$\cos \varphi = \frac{L \omega}{\sqrt{(L \omega)^2 + R^2}}$$

$$\text{and } I_0 = \frac{E}{\sqrt{(L \omega)^2 + R^2}}$$

The arc appears as soon as the contacts separate, and evolution of its voltage in time may appear complex. However u_a still has the sign of "i" and its mean absolute value tends towards U_a (see **fig. 9**).

The mathematical study of i_a , t_a and W_a , based on extended Ohm's law $u - R i - L di/dt - u_a = 0$ is still possible but not so easy.

Moreover, since these calculations do not consider the voltage recovery conditions of real a.c. breaking, the two cases $U_a \geq E$ and $U_a \ll E$ must be analysed:

- if $U_a \geq E$, (see **fig. 10**), the arcing voltage helps to force the current to "0" and to hold it

there, whatever the phase shift " φ " of "i" compared with "u";

- if $U_a \ll E$, breaking is still possible and easier, overall, than in d.c. because of the "natural" zeros of i.

Successful breaking depends on postarcing phenomena at each zero current. In fact, this condition can be summed up by a race between arc dielectric regeneration and mains voltage.

Let us look at two possibilities:

- if the symmetry of U_a acquired at a current zero is greater than mains voltage at that instant (see **fig. 11a**), including TRV, then the dielectric regeneration evolution "curve" remains greater than mains voltage and breaking occurs;

- if the symmetry of U_a acquired at a current zero is less than mains voltage at that instant (see **fig. 11b**), including TRV, then the mains voltage may well break the dielectric regeneration curve if this curve is too slow. In this case, arcing may reoccur and no break occurs, at least not at that current zero!

In both these cases, the power factor $\cos \varphi$ of the circuit to break has considerable influence due to the phase shift of the current zeros compared with mains voltage value.

In particular, if $\cos \varphi \approx 1$, voltage and current values are zero at the same time and breaking is easy.

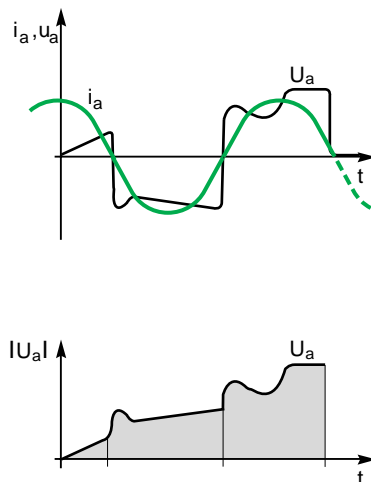

Fig. 9: breaking under a.c. voltage.

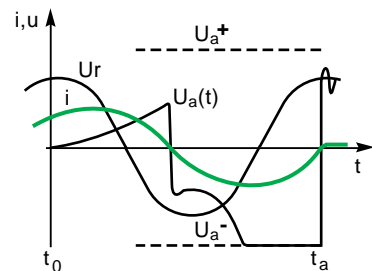

Fig 10: $U_a \geq E$

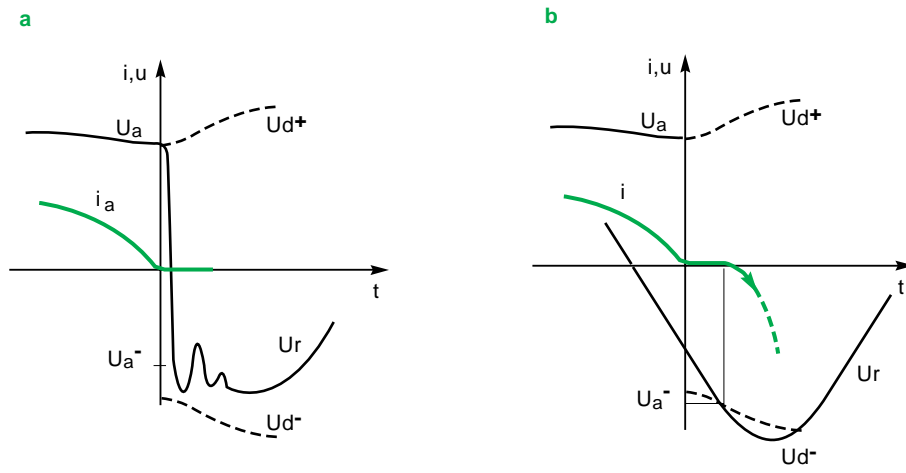

Fig. 11: $U_a \ll E$

4.3 In AC three-phase supply

When the neutral wire is distributed, three-phase voltage breaking conditions are the same as for single-phase voltage, reasoning in phase to neutral voltage, phase by phase.

When the neutral wire is not distributed, the short-circuit point defines a "floating" neutral point (see fig. 12). Thus:

- the first pole breaking has to withstand a recovery voltage equal to an intermediate voltage since the neutral point moves from N to N' (in fact N' moves to N'' in proportion to the arcing voltages on the other two phases). Voltage recovery is thus penalised by a factor of 1.5 (at $\sqrt{3}$);
- the two remaining poles are in series to ensure permanent breaking under phase-to-phase voltage. Breaking is made easier if each phase has an arcing voltage U_a . However, it is not really easier than breaking the same current on just one phase in phase to neutral voltage

($\sqrt{3}/2 = 0.86$ instead of 1; moreover the slightest dielectric weakness in one pole would cause the other pole to break under phase-to-phase voltage).

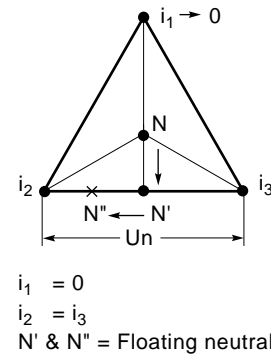

Fig. 12: with non-distributed neutral.

5 Breaking prospective currents (with limitation)

5.1 Definitions

Prospective current

In an installation, this is the current which would flow through a circuit if each connection device pole or the fuse were replaced by a conductor of negligible impedance (IEC 60050).

In a switchgear test circuit, it is the calibration current.

Remember that:

■ **under d.c. voltage**, current evolution takes the form:

$$i = \frac{E}{R} \left(1 - e^{-\frac{t}{\tau}} \right) = I_p \left(1 - e^{-\frac{t}{\tau}} \right) \text{ (see fig. 13) ;}$$

■ **under single-phase a.c. voltage**: the moment "of appearance of the fault" or the moment of closing, compared with mains voltage value, considerably influences evolution of the transient current.

If this moment were characterised by its closing voltage angle α , voltage may be written as:

$$u = E \sin(\omega t + \alpha), \text{ (cf. fig. 14a)}$$

Current evolution takes the shape:

$$i = \frac{E}{R} \left[\sin(\omega t + \alpha - \varphi) - \sin(\alpha - \varphi) e^{-\frac{R}{L}t} \right]$$

with two components:

- an a.c. one, with a phase shift of φ with respect to voltage,
- a d.c. one, tending to zero when t tends to infinity.

Two special cases are defined by:

□ $\alpha = \varphi$, known as the "symmetrical condition" (see fig. 14b)

The current shape is:

$$i = \frac{E}{R} \sin \omega t$$

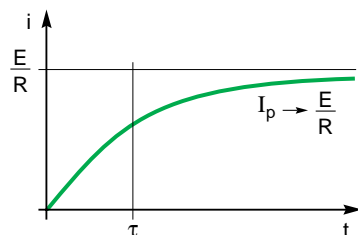

Fig. 13

Right from the start the current has the same curve as in steady state, and a peak value of E/Z .

□ $\alpha = 0$, known as the "asymmetrical condition" (see fig. 14c).

The current curve is given by:

$$i = \frac{E}{R} \left[\sin(\omega t - \varphi) + \sin \varphi e^{-\frac{R}{L}t} \right]$$

Thus the first peak value of the current is a function of the circuit $\cos \varphi$.

■ **under three-phase a.c. voltage** (see fig. 15)

The current in each phase may result in the same special cases (symmetrical and asymmetrical) as in single-phase. In any case, whatever the value of α , there is nearly always:

- a phase in quasi-symmetrical condition,
- a phase in quasi-asymmetrical condition,
- the last phase is said to be in "small loop".

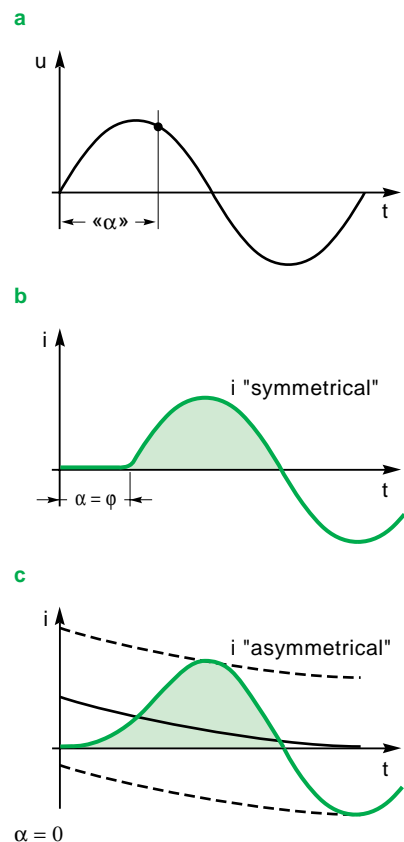

Fig. 14: current evolution under a.c. voltage.

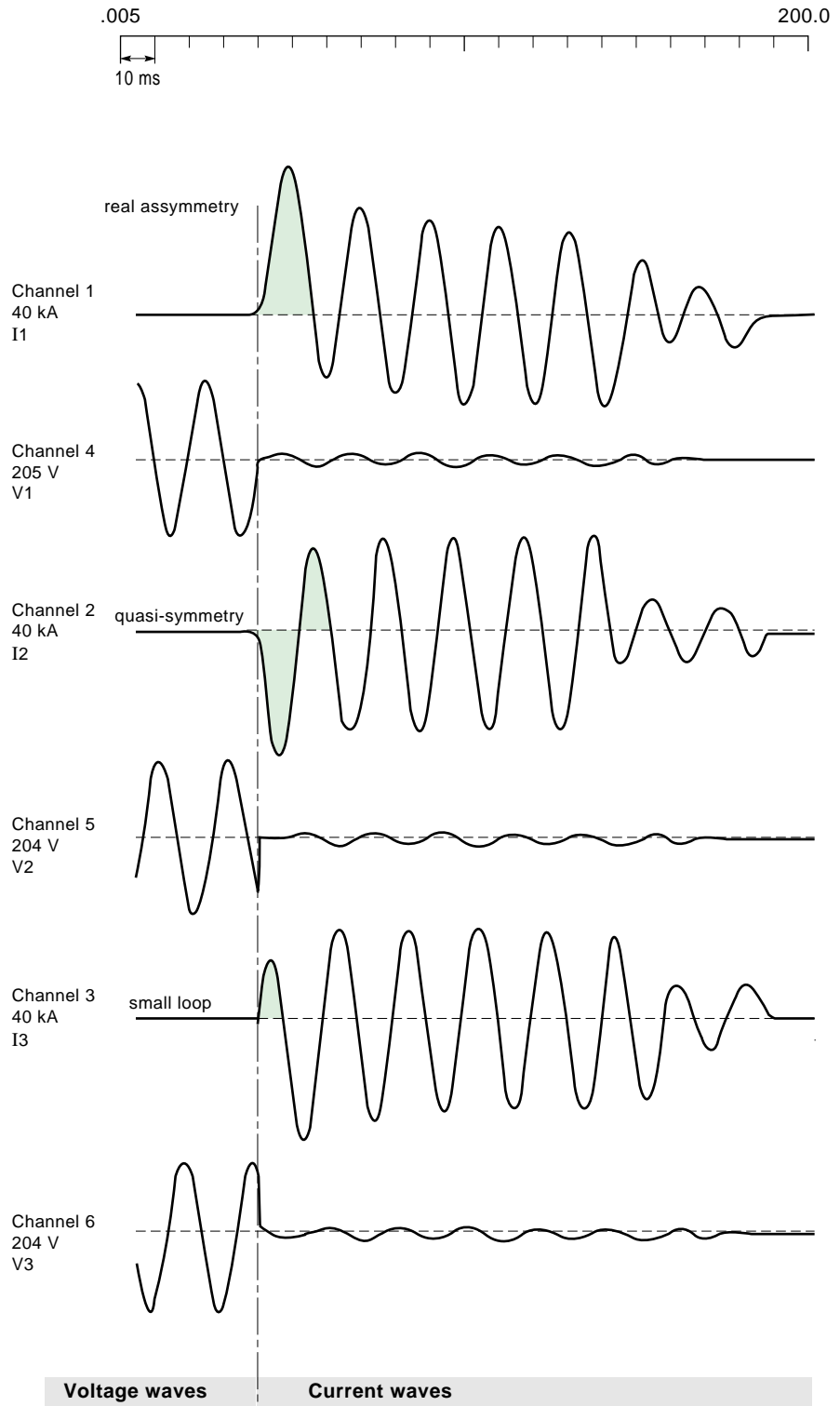

Fig. 15: oscillograms for test circuit breaking under three-phase a.c. voltage, with $\alpha = 0$ (for phase 1).

5.2 Breaking with limitation

The expression means that measures are taken to prevent the short-circuit current from reaching the maximum peak value of its prospective current (see **fig. 16a**).

This objective is an important one and in many cases vital if damage to the installation is to be avoided.

Arc limitation is only possible if arcing voltage quickly becomes and remains greater than mains voltage (cf. **fig. 16b**).

In fact, Ohm's law, $e - R i - L \frac{di}{dt} - U_a = 0$, is used to define the three limitation conditions (see **fig. 16c**):

- creation of an arcing voltage as early as possible;
- increase of this arcing voltage as quickly as possible to obtain $U_a = e - R i$ and thus $L \frac{di}{dt} = 0$, which means that the current has then reached a maximum value \hat{i}_c ;
- holding this arcing voltage, U_a , at as high a value as possible; di/dt is then negative and the current is forced to 0.

In short «**Early, Quickly, High**». Such is the slogan for :

"Using the arc to break...
prospective currents,
...with limitation"

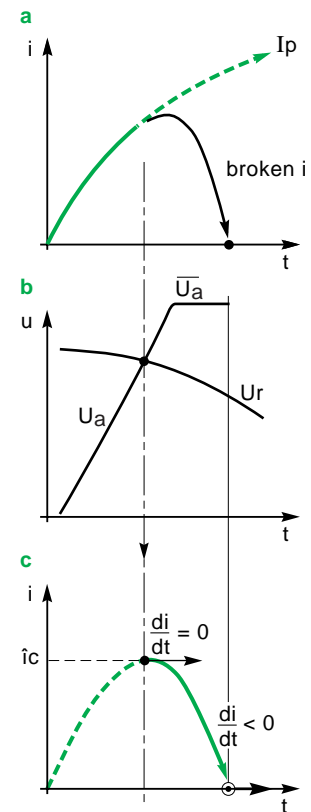

Fig. 16: limitation conditions.

5.3 Under DC voltage

DC voltage takes the form $u(t) = E$

- Until the circuit is opened, current evolves as in the formula:

$$i = \frac{E}{R} \left(1 - e^{-\frac{t}{\tau}} \right) = I_p \left(1 - e^{-\frac{t}{\tau}} \right)$$

- When the circuit is opened, an arcing voltage appears. If it increases rapidly, its overall evolution may be likened to a step function with a rising voltage defined by $u_a = E$ at an instant t_0 (see **fig. 17**).

The current, having reached a value i_0 , then decreases exponentially and disappears after a time $t_a \ll \tau$.

Calculation of arcing energy:

$$W_a \approx \int_{t_0}^{t_a} U_a i_a dt,$$

$$W_a \approx \left[\frac{1}{2} L i_0^2 \right] 2 \frac{U_a}{R i_0} \left[1 - \frac{U_a - U_n}{R i_0} \log \left(1 + \frac{R i_0}{U_a - U_n} \right) \right]$$

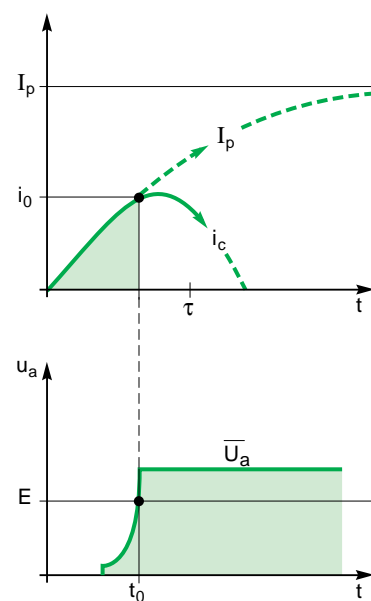

Fig. 17: limitation under d.c. voltage.

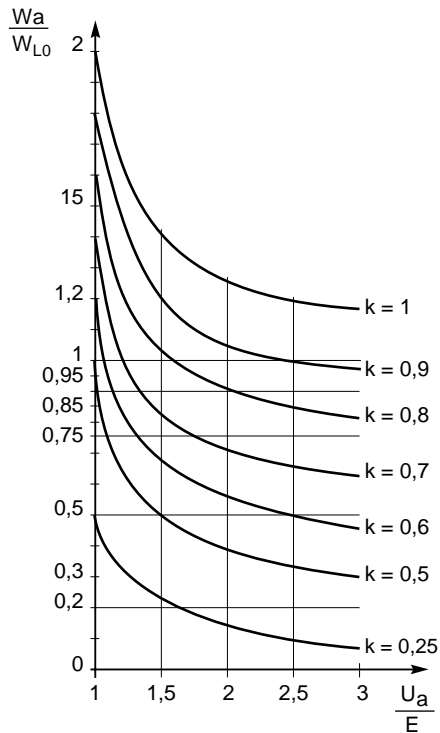

Fig. 18: limitation curves.

Hence the curve network (W_a/W_{L0}), (see fig. 18), when the limitation ratio $k = i_0 / i_p$ is introduced.

Note that the smaller the ratio k , the lower the arcing energy. This energy is «optimal» for $1.5 < U_a / E < 2.5$, which was the case in steady-state current.

5.4 Under single-phase AC voltage

In limitation conditions, this current is broken as though it were temporarily a DC voltage break.

■ In the **symmetrical condition**, in particular, it is virtually equivalent to consider breaking under prospective current with a mains voltage $E = U_n \sqrt{2}$ (see fig. 19a).

■ In the **asymmetrical condition**, limitation is often better since the arcing voltage «breaks» the mains voltage before the current really has chance to evolve (see fig. 19b).

■ In all the «**intermediate**» cases, with the «small loop», breaking with limitation may only occur on the second current half-wave, since the strength of the first half-wave was too low (see fig. 19c).

Remark:

Efficient limitation on high short-circuit currents is only possible if the arcing voltage appears within a time much less than $T/4$.

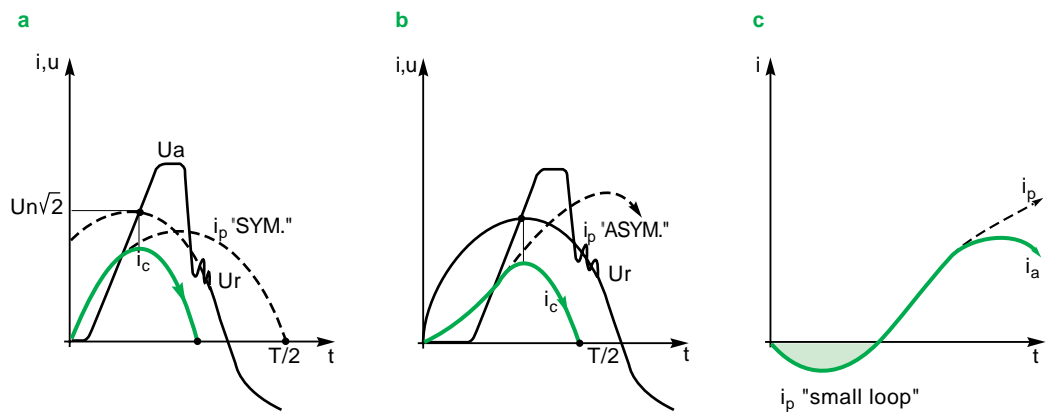

Fig. 19: limitation under single-phase a.c. voltage.

5.5 In a three-phase AC system

Two cases should be considered:

1st case: **separate opening of the poles**

Each phase generates an arcing voltage according to the current flowing through it (see [fig. 20](#)).

At first sight, it is as though:

- one of the phases breaks in the single-phase symmetrical condition, but with voltage recovery in intermediate voltage;
- finally, the other two phases ensure two-phase breaking of a «current tail».

2nd case: **simultaneous opening of the poles**

The current of the phase in the symmetrical condition is the first to react on a tripping device ensuring very fast opening of all poles.

In this case, the arcing voltages develop on all three phases at the same time. It is as though the phase in the quasi-symmetrical condition were broken in its phase-to-phase voltage with a double arcing voltage.

The opening of all poles must take place within a time $< T/4$ and will be most efficient for $< T/8$. The «small loop» phase will then be broken although little current has flown through it.

This breaking behaviour:

- occurs on devices with low overall inertia of their moving parts;
- is sought on large-size equipment with ultra-fast external operating energy (for example, with Thomson effect with capacitive discharge).

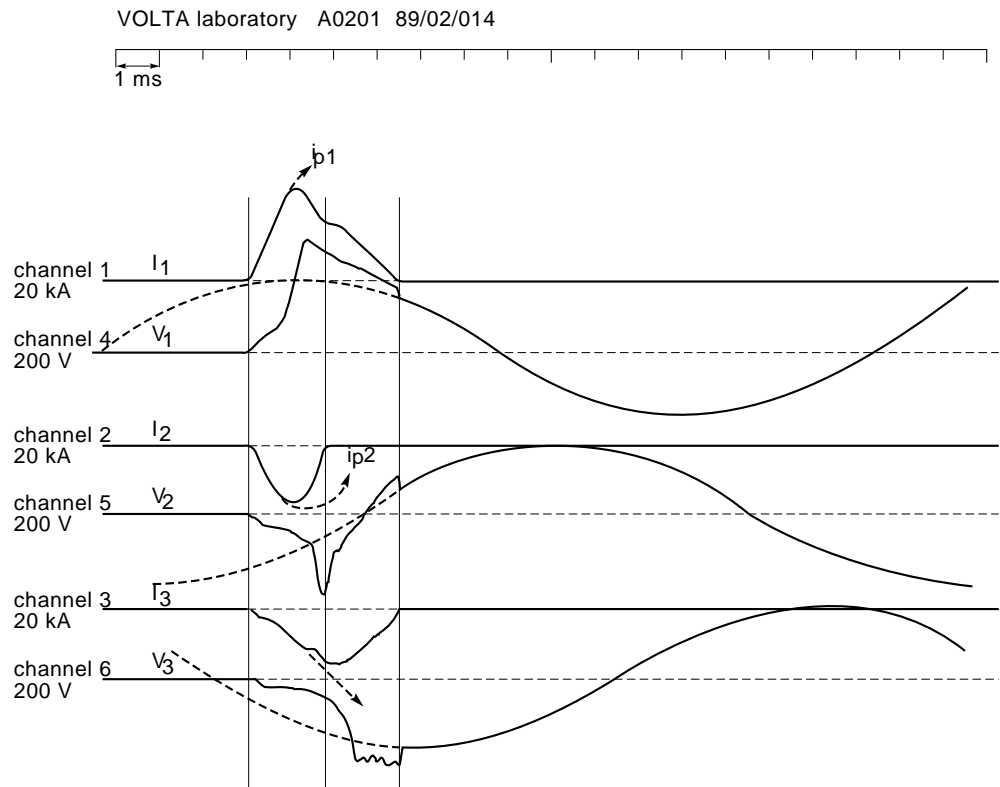

Fig. 20: oscillograms for test circuit breaking in three-phase voltage with separate opening of poles.

5.6 The breaking parameters

The parameters chosen to assess breaking efficiency are:

- broken peak current = \hat{i}_c
(absolute value of the maximum peak current)
Knowledge of this value enables definition of the maximum electrodynamic stresses in the circuit;

■ «thermal stress» or

$$\text{Joule's integral} = \int i^2 dt$$

This term is the recognised expression.

Since the shape of the broken current does not correspond to a simple mathematical function,

this integral is calculated step-by-step by computer.

This integral expresses both thermal and electrodynamic energy stresses on the circuit elements;

■ **breaking time** = t_a

Total breaking time if the circuit is three-phase;

■ **maximum arc voltage** = U_a

Magnitude :

□ 250 to 500 V for standard circuit-breakers,

□ 600 to 900 V for limiting circuit-breakers.

These «overvoltages» do not present a risk since they are lower than the test voltages standardised for LV installations;

■ **arc energy** = $\int U_a i_a dt$

This integral is also calculated step-by-step by computer and expresses the energy consumed in the arcing zone.

Magnitude: 1, 10, 100 kJ according to the device and the currents broken.

It conditions device breaking endurance.

5.7 Fuse breaking technique

A fuse breaks because of the arc.

Its relative simplicity lies in the fact that a carefully calculated filament is brought to its melting temperature by the current flowing through it.

For high currents, the temperature rise resulting in filament melting is of the adiabatic type; its pre-arcing energy is defined by the formula:

$$R \int_0^{t_{pa}} i^2 dt = m c T_f$$

where R = filament resistance,

m = filament mass,

c = thermal capacity,

T_f = melting temperature,

t_{pa} = prearcing time.

This «prearcing» thermal energy is separate from mains voltage.

The arc quickly assumes the length of the melted filament and the arcing voltage takes on a value in accordance with this length and the pressure

appearing in the breaking unit (see **fig. 21**).

This breaking unit can be filled with silica powder which, as it melts, will absorb the arcing energy.

Note: the current "tail" is explained by the «preferential» path created by the arc in the melted silica. The arc decreases in size against the walls which are still warm.

A few remarks about fuses:

■ their action is restricted to high overload and short-circuit currents;

■ some types of fuses have strikers for melt indication purposes, as well sometimes as to indirectly act on an extra breaking device to ensure opening of all phases;

■ following a fuse fault and melt, some «survivors» may have come close to melting and their characteristics may be altered. They may then melt inopportunely under a current lower than their rating. All fuses must therefore be replaced at the same time.

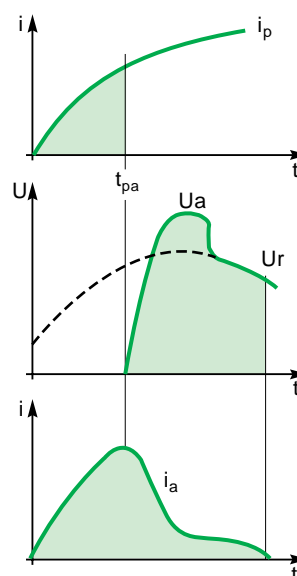
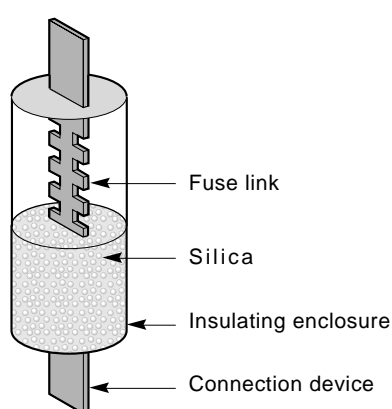

Fig. 21: the fuse, its composition and its characteristic breaking curves.

6 The low voltage circuit-breaker

A circuit-breaker (see **fig. 22**) is a connection device able to close and break a circuit **irrespective of current up to its ultimate breaking capacity: Icu** (refer to standard IEC 60947-2).

Although its main function is to break short-circuit and overload currents by self-energized «reflex» action, it also breaks «normal» currents and overload currents by voluntary action from external sources.

Moreover, after opening, it provides voltage insulation of the broken circuit.

The circuit-breaker's design enabling it to house all these functions in the same case has led to the adoption of specific solutions regarding:

- closing/opening mechanisms;
- trip units;
- pole circuits ;
- breaking elements (contacts, arc chutes...).

The purpose of this chapter is to analyse its functions, technologies and performances.

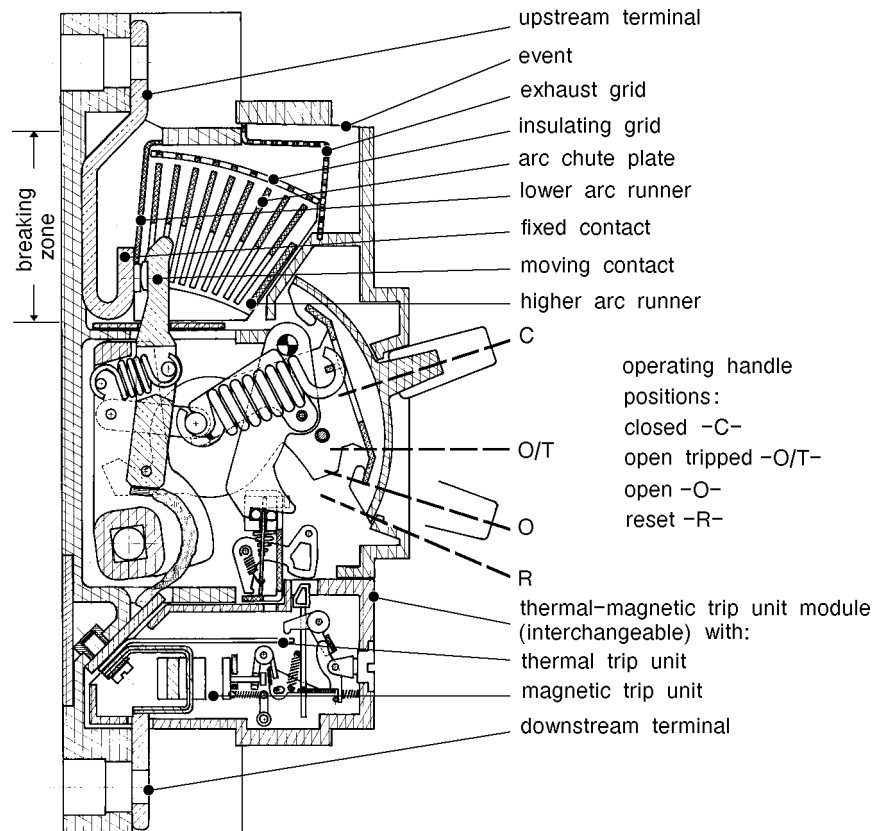

Fig. 22: cross-section of an industrial 400 A LV circuit-breaker.

6.1 Its functions

Circuit closing

By action on the closing mechanism, current flows to supply the load as soon as the slightest contact is established. When energized, some loads absorb currents far greater than rated

current I_n (e.g. motor 7 to 8 I_n for a few seconds). To prevent these overcurrents resulting in dangerous phenomena for the contact zone (erosion by arcs), closing must be prompt, especially for values $\geq 100A$.

If they are to suit all standard cases, circuit-breakers must therefore be able to establish currents 15 to 20 times greater than their rated current.

Specific measures must be taken to perform this function, since a circuit-breaker must always be ready to open again in the event of an installation fault, even during or just after it has closed !

Current conducting

This passive function requires a number of construction precautions if both an acceptable temperature rise and the possibility of quick opening are to be obtained.

Furthermore, if the circuit-breaker is of the discriminated type, it may require a high electrodynamic withstand to accept short-circuit currents during the discrimination time, necessary for the downstream devices to operate.

Circuit opening, current breaking

■ by voluntary action on the mechanism, manual or remote controlled; any current can be broken.

■ by reflex action on the mechanism by the trip unit due to an overcurrent. The circuit-breaker automatically and permanently opens, even if the operating device is held in the "closed" position.

■ by action of an auxiliary trip unit on the mechanism:

Undervoltage, energising, earth leakage current devices... Opening is automatic and permanent: the current can have any value at this time.

Isolation

When the circuit-breaker is open, a certain isolation level is required between the "energized" and "de-energized" parts. The level is checked by insulation tests such as those prescribed by IEC 60947-2 standards:

■ a maximum leakage current test between input and output under max U_e ;

■ an impulse voltage (e.g. 12.3 kV instead of the 9.8 kV required for a device of the same type without this function);

■ a mechanism sturdiness test, known as the "welded contact" (see the Schneider Electric "Cahier Technique" no. 150).

6.2 Its technologies

The mechanisms

The three basic principles are:

■ mechanism «with 2 stable positions» (for circuit-breakers with ratings under 100 A);

■ mechanism with «3 stable positions» particularly used in industrial circuit-breakers (see fig. 22). Their operating device enables:

- sudden closing of contacts, regardless of how they are operated,
- sudden opening of contacts, regardless of how they are operated,
- opening by tripping, suddenly and even if the handle is held. Resetting must then precede reclosing,
- positive break (the operating device can only be padlocked in the "O" position if the contacts are really open);

■ mechanism for high current, more sophisticated circuit-breaker. This type has a device for charging energy storage before closing and opening, thus allowing an "O - FO" cycle without intermediate resetting.

The trip units

In view of trip unit diversity, only the basic principles providing the minimum knowledge required to study overcurrent breaking, are reviewed below:

■ The thermal-magnetic trip units:

□ in overload conditions, significant overheating of a particular current (or temperature in many cases) causes tripping by a "thermal-mechanical" element, generally a bimetal strip. - Trip unit nominal rating is defined by temperature rise conditions in asymptotic heating.

The trip unit can be "compensated" to prevent it being affected by ambient temperature.

- in high overload conditions, temperature rises develop in adiabatic heating. Tripping time thus depends on the circuit-breaker's preliminary temperature rise.

□ in short-circuit conditions, as from a certain current threshold, tripping is performed "instantaneously" by a magnetic circuit which actuates an armature or a core.

This threshold is defined on a current impulse of 200 ms. However its action time is extremely reduced (3 to 5 ms) for high currents;

■ "electronic" trip units

Their prime purpose is evaluation of the current flowing through the circuit-breaker poles to take the appropriate action on a tripping device.

Their advantages are:

- greater precision of target thresholds,
- tripping curves which can be adjusted according to use,
- local or remote information possibilities.

The contacts

LV circuit-breaker contacts are made up of conductive element zones pressurised in the same direction as their possible displacement (see fig. 23), consequently, no "knife" contacts as in many switches.

Two physical phenomena linked to the materials used and to contact force should be noted:

■ **contact resistance (R_c)**

This must be as small as possible since it conditions the ohmic power developed at the contact point which must be discharged by conduction. These temperature rises can accentuate oxidation and corrosion phenomena; to guard against them, contacts may be made of copper up to 100 A and must be made of silver at higher values.

On high currents, the power produced at the contact point may exceed the power which can be dissipated. The contact zone may then be brought to its melting point. Thus in order to prevent contact welding, a heterogeneous pair of materials is normally provided, for example with tellurium or carbon placed in one of the two contact materials. The single contact technique is used up to $I_n = 630A$. For higher values, the multi contact technique is preferred.

■ **contact striction repulsion**

Magnetic interaction between the "radiating" current lines gives rise to a contact repulsion

force known as striction repulsion. Its consequences are damaging since while it lasts:

- contacts erode pointlessly by the arcing energy,
- there is a risk of welding or microwelding if the contacts close,
- "hot spots" are created, promoting arc stagnation and thus thermionic emission; arc extinguishing conditions during its regeneration phase may thus be compromised.

Note that to increase electrodynamic withstand beyond $I_n = 630 A$, striction repulsion also results in use of the multi blades contact technique.

In short, choice of materials and of contact force is decisive for contact resistance, repulsion threshold and for other aspects such as their behaviour to erosion, microwelding, etc...

Moving contact

on high currents over $15 I_n$, the following measures must be taken:

■ for devices which must stay closed, reinforce electrodynamic withstand by a self-energized "compensation" effect. There are several possible diagrams:

□ by mutual attraction: this diagram used in switches prevents opening on high currents (see fig. 24a),

□ by balanced repulsion device, used in circuit-breakers with high rated current (see fig. 24b).

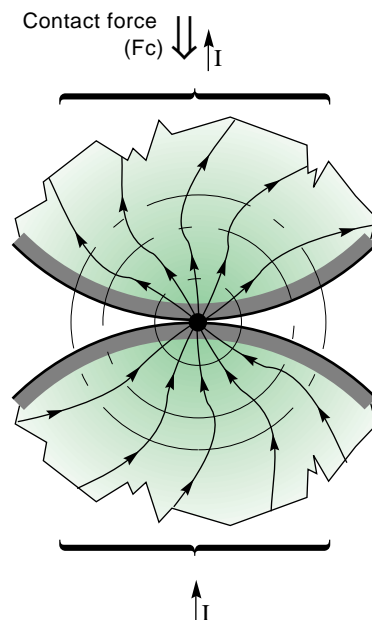

Fig. 23: the LV circuit-breaker contacts are pressed in the same direction as they are moved.

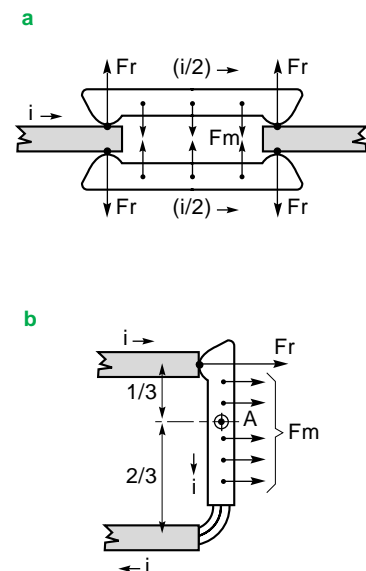

Fig. 24: reinforcement of contact electrodynamic withstand.

Since these circuit-breakers are the main ones, their tripping is often delayed to obtain discrimination. They must therefore have a high electrodynamic withstand, approaching the "20 In" short-circuit values.

■ for devices needing to open and break quickly, enhance moving contact repulsion conditions in order to obtain arcing voltage as quickly as possible. A few diagrams are possible (see **fig. 25**) :

- with simple repulsion loop,
- with double repulsion (often created by a "double contact"),
- with "extractor", a magnetic core pushes or pulls the moving contact.

The repulsion effects can be reinforced by the use of magnetic circuits:

- with effects proportional to the current square:
 - U-shaped swallowing circuit (see **fig. 26a**),
 - U-shaped expelling circuit (see **fig. 26b**),

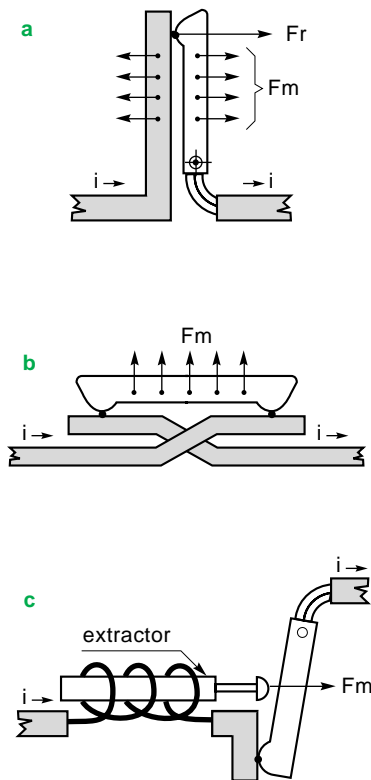

Fig. 25: contact repulsion principle:

- a:** with simple repulsion loop;
- b:** with double repulsion (often created by a "double contact");
- c:** with "extractor", a magnetic core pushes or pulls the moving contact.

□ with effects proportional to the current slope (di/dt), thus particularly effective on high currents (I_{sc}), (cf. **fig. 26c**).

The arc chutes

Their main function is to maintain arcing voltage at a suitable value and absorb the energy generated by the arc (this energy is sometimes phenomenal: if $U_a = 500$ V and $i = 10\,000$ A for 2 ms, then $P_a = 5$ MW and $W_a = 10$ kJ!).

The arc chute must also meet dielectric regeneration conditions sufficient to ensure permanent breaking of the current, despite mains voltage presence.

The physical phenomena to be considered for breaking are no longer solely electrical: thermal phenomena (melting, sublimation, evaporation) aerodynamics and radiation also play a role in each instant's energy balances.

Basically the arc chute sends the arc against an arc plate stack, arranged at right angles to the main arc column in order to:

- split the arc up into the same number of elementary arcs as there are intervals (see **fig. 27a**), each of them thus generating a minimum arcing voltage due to the anode/cathode phenomenon and to its elongation.

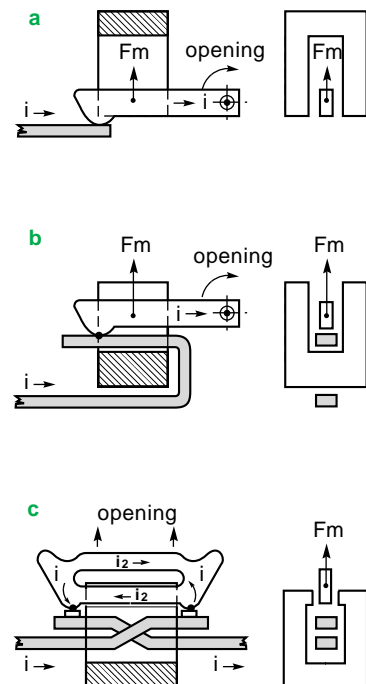

Fig. 26: magnetic contact repulsion devices:

- a:** U-shaped swallowing circuit ;
- b:** U-shaped expelling circuit ;
- c:** repulsion with high di/dt .

Arcing voltage when splitting occurs is calculated as follows:

$$U_a \approx N \times U_{AC} + (L - N e) U_L$$

For example: where $N = 10$, $L = 4 \text{ cm}$,
 $e = 2 \text{ mm}$, $U_{AC} = 30 \text{ V}$ and $U_L = 75 \text{ V/cm}$
 $U_a = 200 + 150 = 350 \text{ V}$

■ store, by temperature rise or temporary arc plate melting, the energy produced under high currents in the plasma column. In actual fact, in particular situations, there is an upper current limit beyond which the arc remains in front of the arc plate stack, (see **fig. 27b**), while continuing to exchange considerable heat with them. Although the arc is no longer split, arcing voltage has the same magnitude.

The zone before chute

This zone is made up of the volume separating the contact separation zone and the beginning of the arc plates making up the arc chute.

Specific precautions must be taken to:

■ prevent the arc stagnating on the contacts. The «lower» arc runner helps by moving the fixed contact arc foot underneath the chute arc plates;

■ promote faster and more extensive arc elongation than that caused by simple mechanical opening of the contacts.

The magnetic effects, already mentioned for moving contact repulsion, will help by acting on the arcing current.

In addition to this «magnetic blowing», a real aerodynamic blowing will occur if the energy of the emerging arc vaporises or sublimates ablative materials by generating overpressures and gases which enhance arcing voltage evolution.

Also should be mentioned the inevitable pressure when interrupting high currents in a confined surrounding. This favours the development of arc voltage, because:

■ the section on the right of the arc column is reduced, and its resistance increased;
 ■ pressure differences between this area (overpressure due to the arc) and the rear side of the arc chute (atmospheric pressure) favours its penetration and confinement in the arc chute.

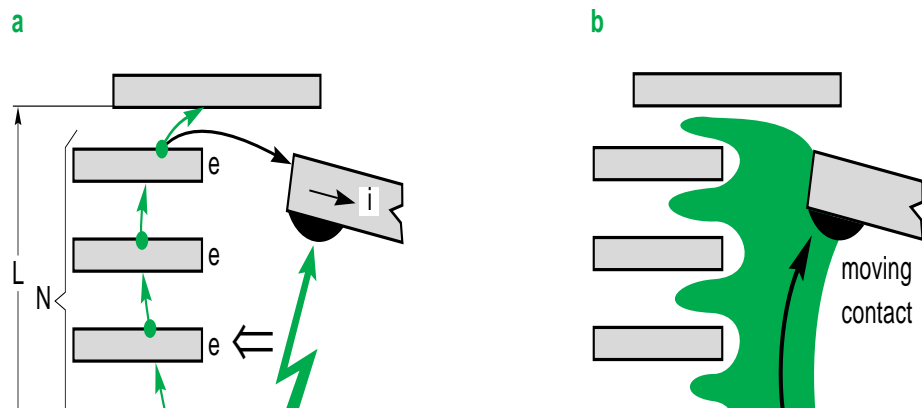

Fig. 27: the arc plates placed in the arc chutes help to extinguish the arc.

6.3 Its performances

A circuit-breaker's performances ensure its suitability for use in a given electrical installation and at a specific point in this installation.

Electrical installations require the use of many circuit-breakers (at installation origin, at line cross-section changes, near certain loads,....) with highly varying performances:

- rated voltages from 400 to 690 volts in three-phase;
- rated currents, I_n , from a few amps to 6300 A according to where they are placed in the installation;
- overload protection devices from 1.3 to 10 I_n according to the elements protected;
- breaking capacities of values often less than 35 kW, but able to reach 150 kA according to installed power;

Special features of LV circuit-breakers

To meet all the needs of electrical distributions in industry and the service sector, a «range of circuit-breakers» is thus required (see **fig. 28**). Circuit-breakers whose characteristics are obtained by technical solutions adapted to their functions and sizes.

In this way the breaking function, made to suit each level, helps ensure the safety of the entire installation.

- protection (of people and equipment),
- availability of energy or continuity of service, in particular through circuit-breaker tripping discrimination.

In LV, discrimination is generally based on two methods: current discrimination and time discrimination.

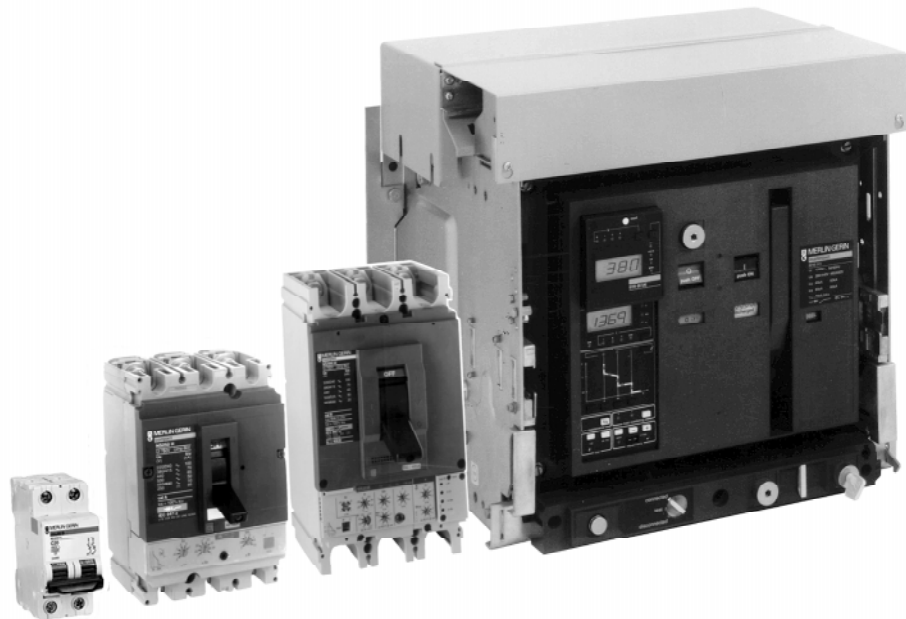

Fig. 28: range of Merlin Gerin low voltage circuit-breakers.

■ the former, reinforced by use of energy discrimination (refer to "Cahier Technique" no. 167) is obtained with A category circuit-breakers as in standard IEC 60947-2. These circuit-breakers have to break the fault current very quickly and considerably limit short-circuit currents.

■ the latter is achieved with B category circuit-breakers. These circuit-breakers, normally the main ones, have to withstand the flow of steady-state fault currents and therefore need an excellent electrodynamic withstand.

Excellent short-circuit current limitation

(also refer to "Cahier Technique" no. 163)

This is particularly aimed at for circuit-breakers less than or equal to 630 A.

These circuit-breakers develop an arcing voltage of 600 to 900 V in small volumes. It is easier to obtain this voltage using double breaking systems (by combining the diagrams in figures 25b and 26b) and by implementing a rotating type moving contact which has the added advantage of simplifying production of one breaking unit per pole (see **fig. 29**).

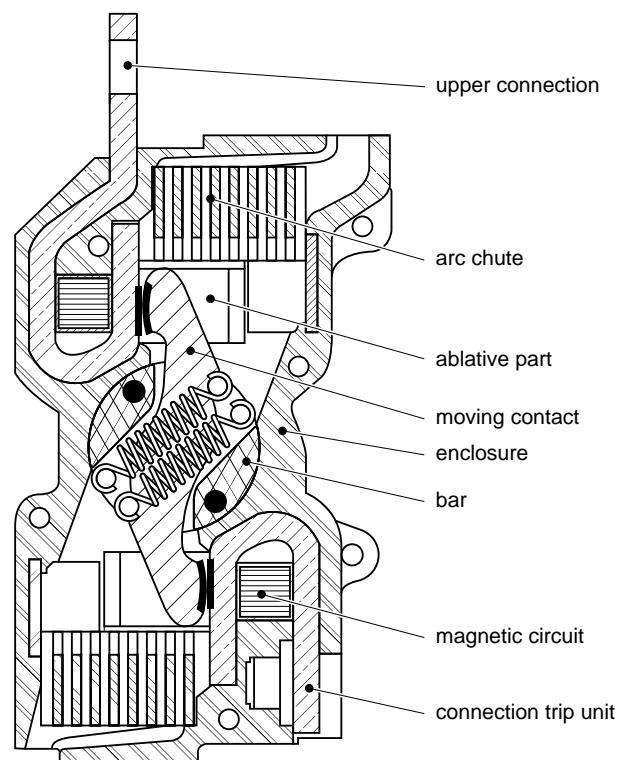

Fig. 29: breaking unit of a rotating contact LV circuit-breaker (Compact NS - Merlin Gerin).

It is thus possible to break 100 kA in 2.5 ms using a 250 A circuit-breaker.

Excellent electrodynamic withstand

This is aimed at for circuit-breakers equal to or greater than 800 A.

This aim requires compensation of electromagnetic forces, which is easier to achieve with simple breaking (diagram 24b) all the more so since the wide opening (distance between contacts) of these larger devices (importance of conductive parts for high current flow) also enables a high arcing voltage (600 to 900 V) to be obtained.

A 3200 A circuit-breaker thus breaks "100 kA" in 15 ms (without tripping delay) as well as withstanding 75 kA for 3 s (see. **fig. 30**).

Proven performances

Circuit-breaker performances are evaluated and guaranteed by the carrying out of standardized tests (refer to IEC 60947-2 and NF C 63-120).

Thus, with respect to "breaking", tests are used to verify for example:

- endurance under I_n ,
- overload endurance (e.g. under $6 I_n$),
- breaking capacities by cycles :
 - O-FO at I_{cu} , ultimate breaking capacity,
 - or O-FO -FO at I_{cs} , service breaking capacity with $I_{cs} \leq I_{cu}$.

Note:

The publication of standard IEC 60947-2, dealing with industrial LV circuit-breakers, is the subject of "Cahier Technique" no. 150 which completes the details given above.

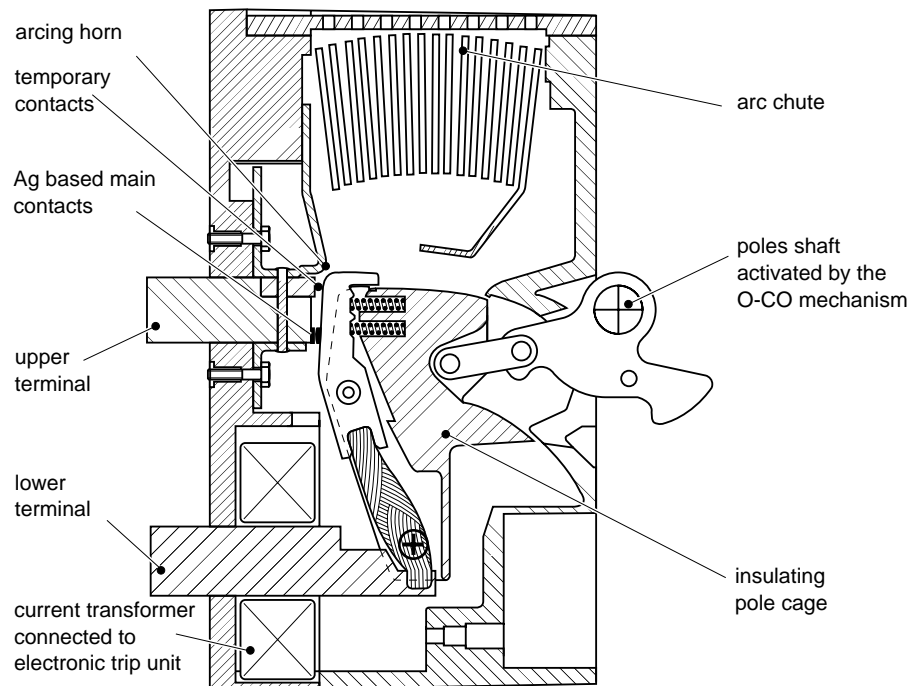

Fig. 30: breaking unit of a LV circuit-breaker with excellent electrodynamic withstand (Masterpact - Merlin Gerin).

7 Conclusion

The future of the arc?

The electric arc continues to be an excellent means of breaking with current limitation in low voltage.

Moreover, low voltage circuit-breakers have been considerably enhanced as a result of developments in know-how, materials and use of electronics.

For many decades to come, electric circuit protection will therefore continue to require circuit-breakers with «arc control».

Bibliography

Standards

- IEC 60947-2: Low-voltage switchgear - Part 2: circuit-breakers.
- IEC 60050: International electrotechnical vocabulary.
- NF C 63-120 (French Standards): Appareillage à basse tension - 2ème partie : disjoncteurs.

Cahiers Techniques Schneider Electric

- Development of LV circuit-breakers to standard IEC 947-2.
Cahier Technique no. 150
E. BLANC
- LV breaking by current limitation.
Cahier Technique no. 163
P. SCHUELLER
- Energy based discrimination for low voltage protective devices.
Cahier Technique no. 167
R. MOREL - M. SERPINET

Schneider Electric

Direction Scientifique et Technique,
Service Communication Technique
F-38050 Grenoble cedex 9
Fax : (33) 04 76 57 98 60

DTP : AK.
Edition : Schneider Electric
Printing : Imprimerie du Pont de Claix - Claix - 1000.
- 100 FF-