

Cahier technique no. 196

## Integration of local power generation in industrial sites and commercial buildings

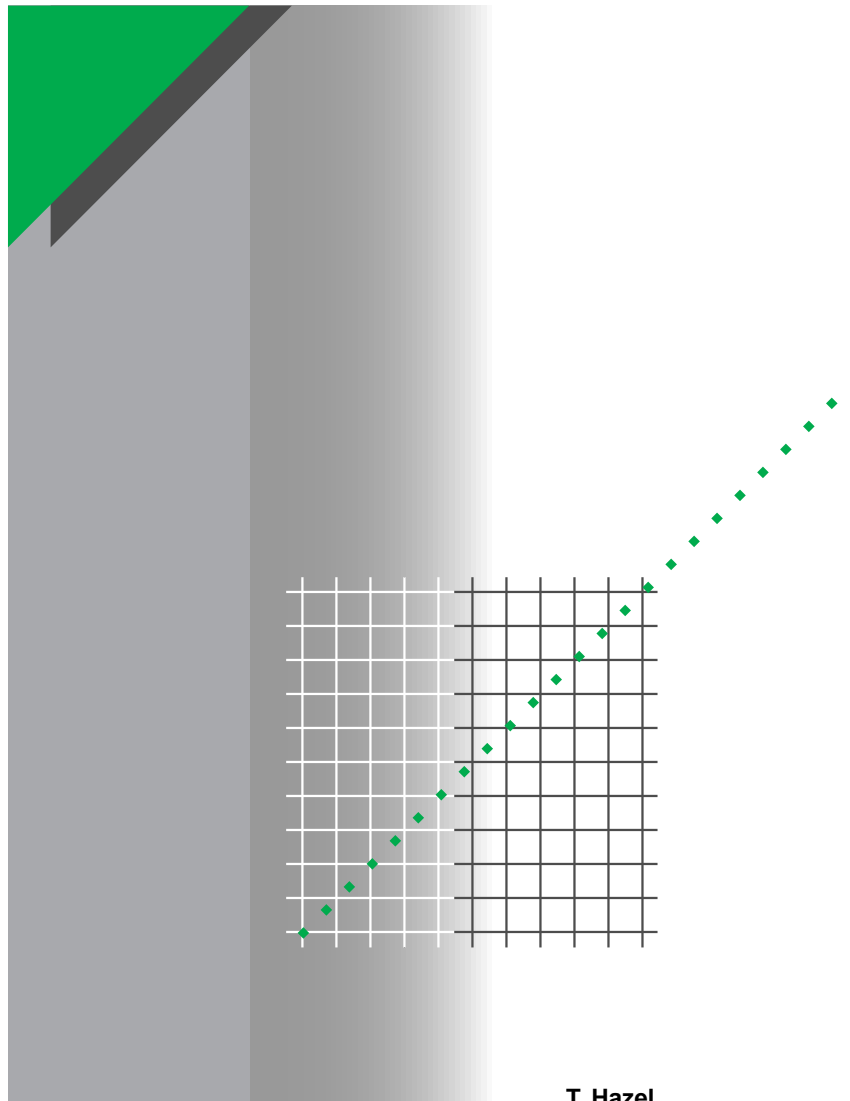

Merlin Gerin

Modicon

Square D

Telemecanique

T. Hazel

"Cahiers Techniques" is a collection of documents intended for engineers and technicians, people in the industry who are looking for more in-depth information in order to complement that given in product catalogues.

Furthermore, these "Cahiers Techniques" are often considered as helpful "tools" for training courses.

They provide knowledge on new technical and technological developments in the electrotechnical field and electronics. They also provide better understanding of various phenomena observed in electrical installations, systems and equipments.

Each "Cahier Technique" provides an in-depth study of a precise subject in the fields of electrical networks, protection devices, monitoring and control and industrial automation systems.

The latest publications can be downloaded from the Schneider Electric internet web site.

Code: <http://www.schneider-electric.com>

Section: **Experts' place**

Please contact your Schneider Electric representative if you want either a "Cahier Technique" or the list of available titles.

The "Cahiers Techniques" collection is part of the Schneider Electric's "Collection technique".

### **Foreword**

The author disclaims all responsibility subsequent to incorrect use of information or diagrams reproduced in this document, and cannot be held responsible for any errors or oversights, or for the consequences of using information and diagrams contained in this document.

Reproduction of all or part of a "Cahier Technique" is authorised with the prior consent of the Scientific and Technical Division. The statement "Extracted from Schneider Electric "Cahier Technique" no. ...." (please specify) is compulsory.

# no. 196

## Integration of local power generation in industrial sites and commercial buildings

---

### Terence HAZEL

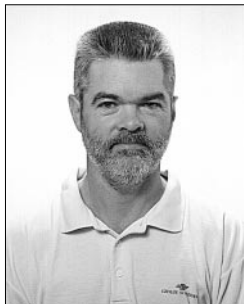

Terry Hazel received his BSc in Electrical Engineering from the University of Manitoba Canada in 1970. He then worked in Perth Australia for a year as power coordination engineer, and in Frankfurt Germany as a consulting engineer until he joined Merlin Gerin in 1980. For 15 years was the technical team leader for several major international projects involving process control and power distribution. He has since been with the tendering section of the industrial projects department and often meets with clients during the front end engineering stage to discuss and compare the various possible electrical distribution systems. He is an active member of IEEE and has presented papers dealing with electrical power distribution at Industry Applications Society conferences.

---

# Lexicon

---

**Black start:** The capability of starting generator sets without the presence of a utility supply.

**Damage curve:** A current-versus-time curve showing the allowable limit without permanent damage to equipment.

**Equipment commissioning:** Performance of the testing and adjustment at site leading up to and including the energization of a piece of equipment. An example would be the operation of one generator set.

**Frequency droop:** The absolute change in frequency between steady state no load and steady state full load, typically 4%. An increase in power output results in a decrease of frequency for generator sets operating alone in this mode.

**Isochronous speed governing:** Governing with steady-state speed regulation of essentially zero magnitude.

**Load sharing:** Centralized elaboration and sending of set points for generator set loading. This ensures that all sets will share the load in an equal manner proportional to their power rating.

**Load shedding:** Voluntary disconnection of low priority loads when the available power is insufficient to supply the total plant load.

**Residual voltage:** The voltage on a busbar after disconnection from the supply. This voltage is generated by rotating machines which remain connected to the busbar.

**Spinning reserve:** The difference between the total available capacity of all generating sets already coupled to the system and their actual loading.

**Static switch:** A fast acting switch normally consisting of a power electronics device which will transfer the load from the power conversion module of a UPS to another supply without delay or unacceptable transients.

**Synchronism-check relay:** A verification relay whose function is to operate when two input voltage phasors are within predetermined limits.

**Synchroscope:** An instrument embodying a

continuously rotatable element whose position is a measure of the instantaneous phase difference between the voltages across a circuit-breaker.

**System commissioning:** Performance of additional testing and adjustments at site of equipment which have been commissioned to ensure correct operation of the system comprised of the equipment. An example would be the parallel operation of several generating sets including synchronizing, and load shedding features.

**System stability:** A system is considered stable if bounded input disturbances result in bounded output disturbances. For an electrical distribution system, changes in load, faults, switching operation, etc. will not cause wide fluctuations in voltage or frequency if it is stable.

**Unit substations:** A substation containing the electrical distribution equipment necessary for supplying the loads of a particular plant production unit. It typically contains medium voltage switchgear, power and distribution transformers, low voltage switchgear and MCC.

**Voltage restrained overcurrent relay:** An overcurrent protection relay having a voltage input which opposes the typical response of the relay to the current inputs. This is used for generators since they deliver much lower short-circuit currents than utility connections having the same capacity.

**Voltage waveform distortion:** The difference between the actual voltage waveform and a pure sinusoidal waveform, often expressed as total harmonic distortion,

$$THD = \frac{\sqrt{\sum U_h^2}}{U_1}$$

where  $U_h$  is the harmonic voltage and  $U_1$  is the fundamental of the voltage waveform.

**X/R ratio:** The ratio of the electrical distribution system inductance to the resistance. This ratio determines the time constant of the d.c. component of the short-circuit current which is an important factor in defining the rating of high-voltage circuit-breakers.

# Integration of local power generation in industrial sites and commercial buildings

Engine driven alternating current generator sets are often used in remote industrial sites as a prime source of electrical energy. They are also extensively used in both industry and commercial buildings as a source of back-up power. This cahier technique discusses most of the subjects which have to be handled when implementing engine driven alternating current generator sets having rated powers up to 20 MW.

## Contents

<b>1 Types of engine generator sets</b>		<b>p. 4</b>
<b>2 Rated power for generator set applications</b>		<b>p. 5</b>
<b>3 Typical applications</b>	3.1 Stand-by generator sets	<b>p.7</b>
	3.2 Production generator sets	p. 9
<b>4 Operation of generator sets</b>	4.1 Starting and stopping of generator sets	<b>p. 11</b>
	4.2 Stand alone operation	p. 12
	4.3 Parallel operation with utility supply	p. 12
	4.4 Parallel operation with other generator sets	p. 12
<b>5 Transfer schemes and synchronization</b>	5.1 Automatic transfer on loss of supply	<b>p. 14</b>
	5.2 Maintenance transfer	p. 14
	5.3 Synchronization of generator circuit-breaker	p. 14
	5.4 Synchronization of bus-tie, bus coupler, or utility incoming circuit-breakers	p. 15
<b>6 Generator set protection</b>	6.1 General protection philosophy	<b>p. 16</b>
	6.2 Electrical protection	p. 17
	6.3 Machine protection	p. 18
<b>7 Connection of generators to electrical network</b>	7.1 Connection to generator circuit-breaker	<b>p. 19</b>
	7.2 Connection of generator neutral point	p. 19
<b>8 Load shedding</b>		<b>p. 20</b>
<b>9 Interfacing generator with electrical distribution system</b>	9.1 Typical split of supply between generator set manufacturer and switchgear manufacturer	<b>p. 21</b>
	9.2 Information to be exchanged	p. 21
	9.3 Integration of generator set into electrical distribution supervisory system	p. 22
<b>10 Installation of engine generator sets</b>	10.1 Location	<b>p. 23</b>
	10.2 Air intake and exhaust	p. 23
	10.3 Compliance with local regulations	p. 23
	10.4 Special tools and spare parts	p. 24
<b>11 Conclusion</b>		<b>p. 24</b>
<b>Bibliography</b>		<b>p. 24</b>

# 1 Types of engine generator sets

The main types of prime movers used in engine driven generator sets for industrial sites and commercial buildings are Diesel engines, gas turbines, and steam turbines. Turbines are used mainly for production sets whereas Diesel engines can be used for both production and standby sets.

Most of the topics covered in this cahier technique are not dependant on the type of

prime mover used, and therefore the general term generator set will be used.

The choice of the prime mover is determined by such considerations as the availability and type of fuel and is not covered in this cahier technique.

Since Diesel engines are very often used some specific information about Diesel generator sets will be given.

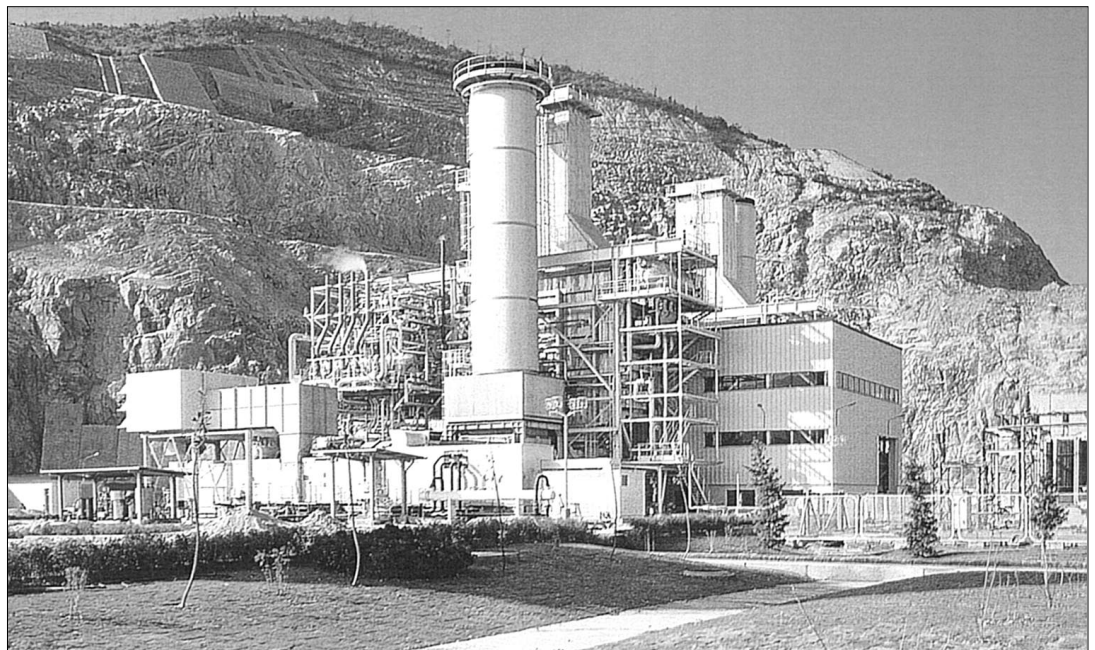

Above is an example of a combined oil treatment and power plant. It incorporates two gas turbine generator sets with an output of approx. 100 MW.

*(Courtesy of GE Energy Products France S.A.).*

In most industrial plants, however, power generation is not the main purpose. The plant may have one or several Diesel generator units to produce the necessary electrical power, mainly for stand-by, and possibly for local consumption requirements. The picture shows a 1 MW Diesel generator unit.

*(Courtesy of Hovvenaghell/Hennequin S.A.).*

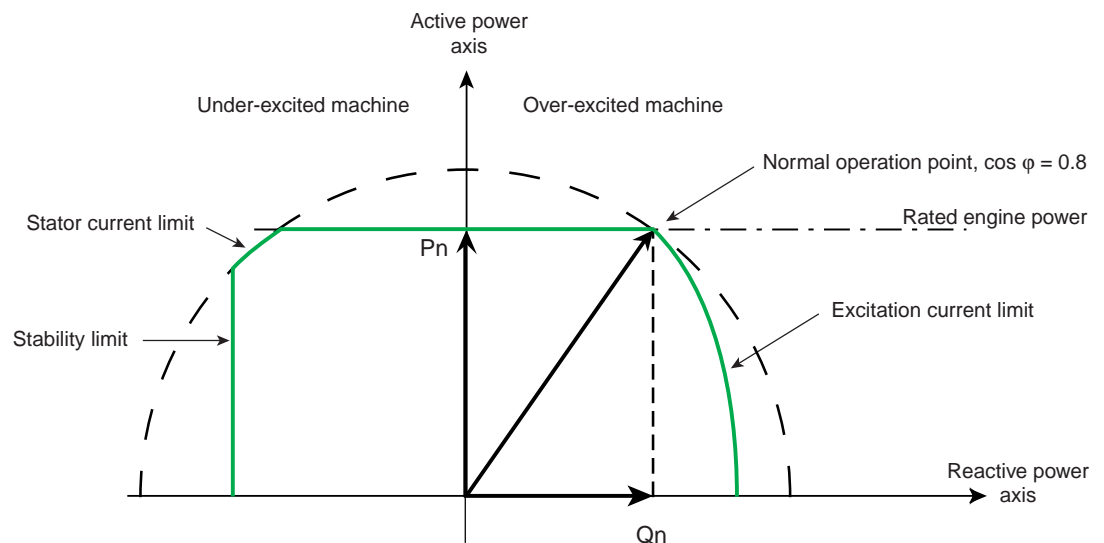

**Fig. 1:** different configurations of local generation

## 2 Rated power for generator set applications

The power output requirement for the generator set is probably the most important criterion to be defined. The output of a generator set is typically

defined on the active/reactive power graph as represented in **figure 2**.



**Fig. 2:** active/reactive power graph showing operating limits

The active power output depends on the type of fuel used, and on site conditions including ambient temperature, cooling medium temperature, altitude, and relative humidity. It also depends on load characteristics such as possible overloading and load variations over time. The ISO 3046-1 standard for Diesel engines defines three different types of power ratings, and a standard definition of overload capability.

The different power ratings are:

- **continuous power rating:** The engine can supply 100% rated power for an unlimited time. This rating is normally used for production sets.
- **prime power rating:** The engine can supply a base load for an unlimited time, and 100% rated power for a limited time. The base load and acceptable time for 100% rated power are different for each manufacturer. Typical values are a base load of 70% of the rated power, and 100% rated power during 500 hours per year.

■ **standby power rating:** This is the maximum power that the engine can deliver and is limited in time, typically less than 500 hours per year. This rating should only be applied to generator sets which are used exclusively for emergency power. Since the engine is incapable of supplying more power, a security factor of at least 10% should be used when defining the standby power rating.

The standard overload capacity is defined as 10% more power during 1 hour for every 12 hours of operation. There is no overload capacity with a standby power rating. Most manufacturers allow the standard overload capacity with the continuous power rating and the prime power rating, but since there are exceptions, the overload capacity should always be specified together with the type of power rating used. A typical example is a Diesel engine having a continuous power rating of 1550 kW, a prime power rating of 1760 kW, and a standby power rating of 1880 kW.



When generator sets are used as a prime source of electrical energy the following points should be considered:

- provide for parallel operation with other sets and/or with utility,
- allow for long maintenance periods (overhaul),
- ensure black-start capabilities,
- use low speed equipment for long life (maximum 750 rpm for Diesel engines).

When used as a standby source:

- ensure quick and reliable start-up and loading,
- implement reliable load shedding to avoid overloading or stalling,
- allow for periodic testing under load,
- provide for parallel operation with utility if set is used during peak loads,
- supply magnetizing current for distribution transformers.

One common application for standby generators is to supply UPS (uninterrupted power supply) equipment during power outages. Since the

generator has a relatively high impedance as compared to a utility supply, voltage waveform distortion can occur due to harmonic currents generated by the UPS. Generator manufacturers normally derate their machines by up to 60% to ensure correct voltage waveforms when loads are UPS equipment without harmonic current filtering. The engine must also be able to supply the power absorbed by the UPS which is determined by

$$P = \frac{\text{UPS output kW} + \text{battery recharge kW}}{\text{UPS efficiency}} + \text{auxil. load}$$

For preliminary generator set sizing where detailed UPS information is unavailable, the battery charger kW can be estimated to be 25% of the UPS output kW, and the UPS efficiency can be estimated to be 90%. Final determination of the generator set should be based on specified values of acceptable voltage distortion, and the actual UPS data such as efficiency, and harmonic currents.



# 3 Typical applications

## 3.1 Standby generator sets

The typical supply of essential loads for commercial buildings, small industrial sites or for emergency power to unit substations in a larger site, is shown in **figure 3**.

Under normal operating conditions the essential load is supplied from the utility supply. Upon loss of this supply the bus-tie circuit-breaker Q3 is tripped, the generator set is started, and then load is supplied by the standby generator set by closing the generator circuit-breaker Q2.

Critical loads which cannot accept any power outage are supplied by the UPS. The UPS is equipped with a static switch which will immediately bypass the rectifier/inverter module

in case of an internal fault and thus ensure a continuous supply of electrical power.

Typical generator set sizes for this scheme are 250 kVA to 800 kVA.

The advantage of this scheme is its simplicity and clarity. All essential loads are connected to the same busbar as the generator set and therefore no load shedding is required. UPS backup time can normally be limited to 10 minutes since the UPS will be supplied by the emergency supply.

Both the normal and the backup supply to the UPS should be taken from the essential busbar.

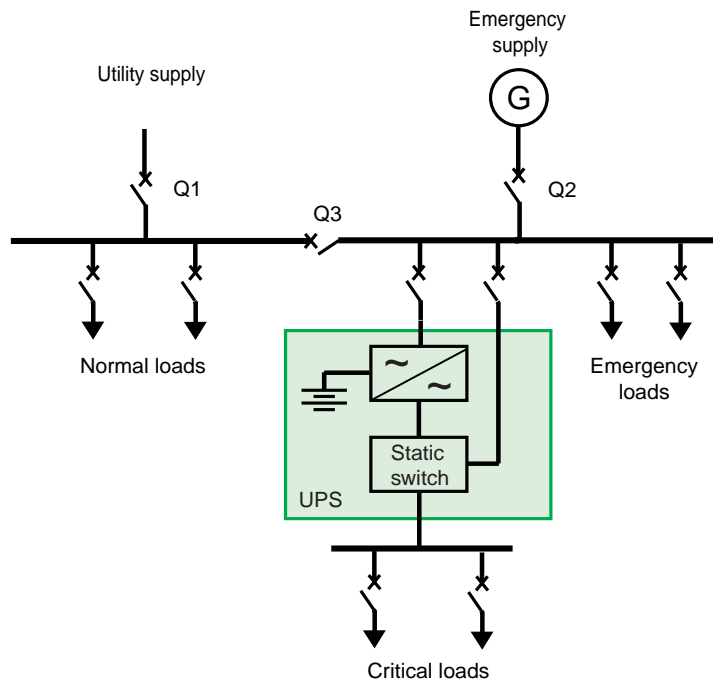

**Fig. 3:** typical emergency supply for small industrial sites

For large industrial sites a centralized emergency power supply system as shown in **figure 4** is often used. The main emergency switchboard is normally supplied from the utility, although in some sites

one of the generator sets may be in constant operation. The emergency switchboard is designed to allow generator sets to operate in parallel and also to be connected to the utility supply.

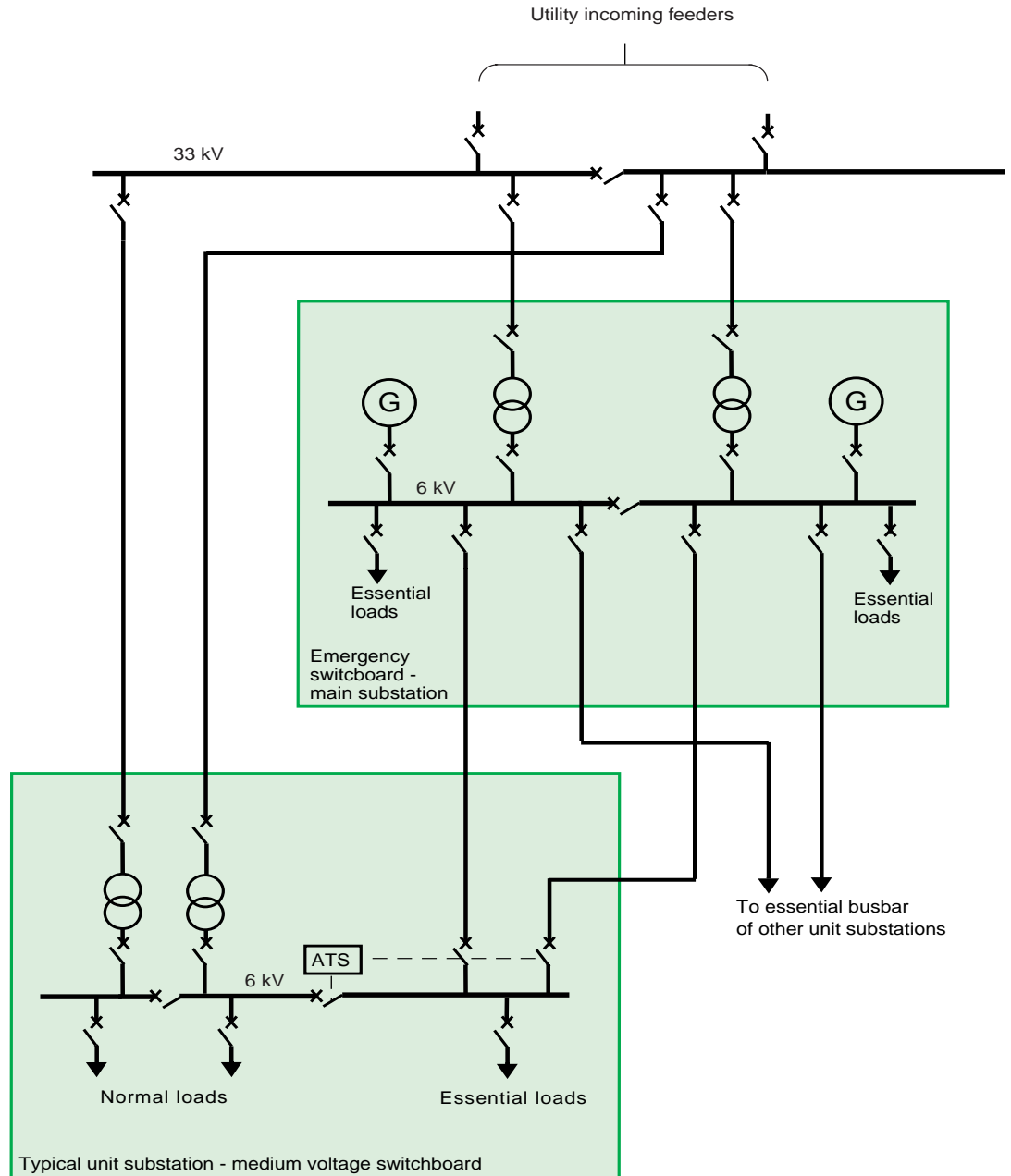

(ATS: Automatic transfer system)

**Fig. 4:** typical emergency supply for large industrial sites

The automatic transfer from the utility to the emergency supply is performed in each unit substation. Since the emergency switchboard is normally energized, fast transfers (described in section 5.1) without loss of plant load can be used.

The use of a centralized emergency supply has the following advantages:

- fewer generator sets for the site (normally maximum of 2),
- permanently energized emergency supply allowing fast transfer schemes to be used,
- no loss of emergency supply due to maintenance of one generator set.

Generator sets for such systems are normally in the 1-4 MW range.

### 3.2 Production generator sets

For remote sites having no utility supply, several generator sets are used. A typical distribution system is shown in **figure 5**.

The number of sets N will depend on the power required, but since generator sets require periodic maintenance, plant power should be able to be supplied by N - 1 sets without any load shedding.

The generator set size should be such that they are loaded at least 50%. A poor load factor can

be detrimental to the sets. For example Diesel engines loaded at less than 30% will not achieve a good operating temperature resulting in poor combustion and degrading of lubrication oil.

Plant operation at N - 2 sets should also be considered, this case occurring when one set is being maintained and there is a loss of an additional set.

The highest initial load factor F that can be used with N installed generators such that load

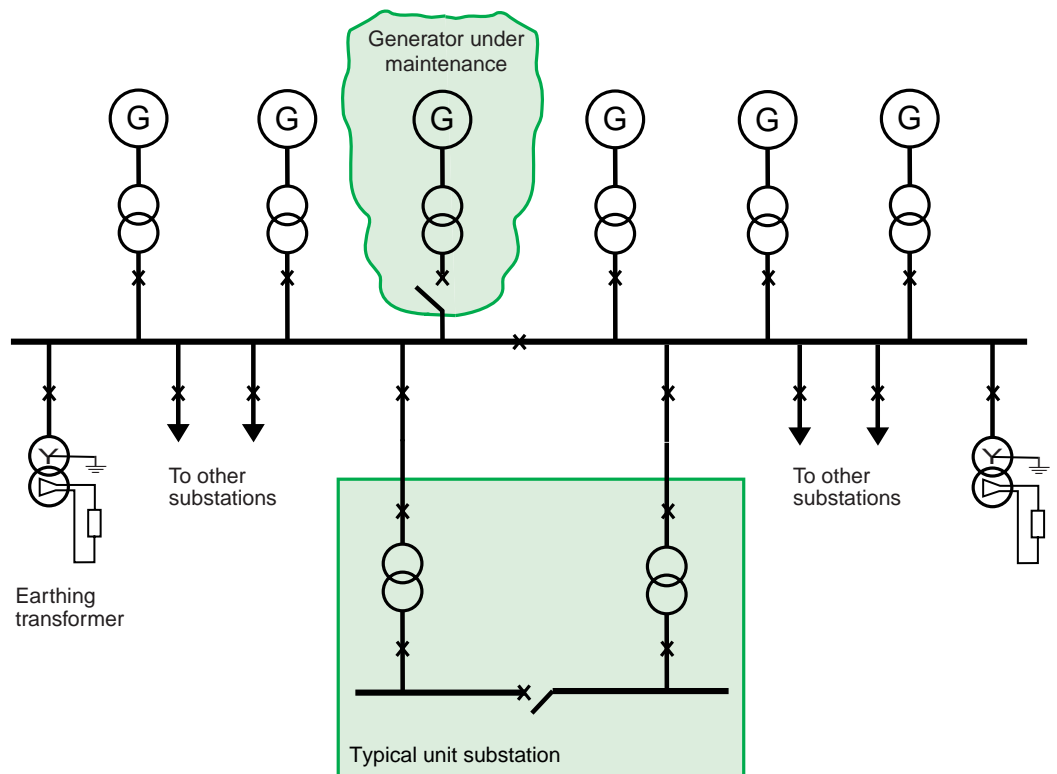

**Fig. 5:** industrial site without utility supply

shedding is not required for N - 2 operation can be determined from:

$$F = \frac{N-2}{N-1}$$

For example the highest load factor for N = 6 will be 80%.

Bus-tie circuit-breakers are often used for maintenance purposes. During normal plant operation all bus-tie circuit-breakers are normally closed. Short-circuit calculations should always take operation with N generators into account since it is normal to connect standby sets prior to switching off sets for maintenance.

A power supply using local generation is generally much weaker than a utility supply and therefore it is probable that load shedding will be required to maintain system stability during fault conditions. Determination of how much load must be shed requires dynamic simulation of the network for different fault conditions such as a loss of a generator or a short-circuit. Prior to the study it is

necessary to determine which operating configurations are to be considered. Operating conditions with the bus-tie circuit-breaker both in the open and the closed positions will greatly increase the complexity of the load shedding system since each busbar can be operated independently and will require specific load shedding criteria. For most plants it is recommended that only the standard operating configuration be used for the dynamic simulations and definition of the load shedding strategy.

Figure 5 shows each generator having its own transformer. The use of generator transformers has several advantages:

- provides flexibility in the choice of generator voltage,
- reduces peak short-circuit current at main board,
- allows use of high impedance generator grounding (reduces possible damage to generator).

## 4 Operation of generator sets

### 4.1 Starting and stopping of generator sets

Since Diesel generator sets are often used for emergency power, it is necessary that steps be taken to ensure that the set will start correctly and quickly when required.

An example of measures to be taken is lubrication, and heating of the cooling water when the set is not operating. The Diesel generator set manufacturer should list all such measures and the design should take into account the availability of all auxiliary supplies necessary during times when set is not operating.

A starting time of 15 seconds from the start order to the closing of the generator circuit-breaker can be guaranteed by manufacturers. Specifying shorter starting times should be avoided since the decrease in starting time will be small and could increase the cost of the set. Critical equipment must be supplied by an UPS in any case.

Two techniques are commonly used for starting. These are compressed air and battery, compressed air generally being used for larger sets. The starting equipment should be designed for a minimum of 3 consecutive starts. It should be carefully monitored in order to enable preventive maintenance to be carried out prior to a failure during an attempted start. Failure to start is most often due to a problem with the starting battery. Where reliable starting is essential, consideration should be given to using compressed air.

When a generator is operating in parallel with another source, it will be synchronized as described in section 5.3 hereafter, and gradually loaded.

When a generator set is operating alone, the load will be applied in one or more steps. The variation in frequency and voltage will depend upon the size of the step loads. As an example, step loads of 90% can be applied to a Diesel generator set without the frequency varying more than 10% and the voltage more than 15%.

Should specific limits on frequency and voltage variations be required, they should be specified together with the type of load which is to be connected. This information should include motor starting characteristics such as the starting current, and the type of starting (direct-on-line, wye-delta). Several steps may be required

should the frequency and voltage tolerance be small.

When stopping a generator set, the power output should be reduced to zero by transferring the load to other sources, and the circuit-breaker then tripped. The generator set should be run for several minutes to allow it to cool down prior to shutdown. In some cases the cooling system should continue to operate after shutdown in order to remove latent heat from the machine. Manufacturer's recommendations for shutdown should be followed.

Generator set start and stop sequences should be handled by the generator set control equipment.

Generator sets should be operated periodically. For installations where short power outages are not critical, opening the normal incoming circuit-breaker will cause the set to start and automatically pick up the emergency load. After the required minimum operating time, the generator circuit-breaker can be tripped and the normal source circuit-breaker closed.

For plants where power outages mean unacceptable production losses, it must be possible to test generator sets without first switching off the supply. This is normally done by using a maintenance transfer. The generator set is started, and after it is ready to take load, it is synchronized to the incoming supply (see section 5.3 below).

The generator circuit-breaker (or bus-tie circuit-breaker depending on the scheme) will then be closed and the generator will thus be paralleled with the incoming supply. The closing of the circuit-breaker will cause tripping of the incoming supply and the loads will be supplied by the generator. The transfer to the normal incoming supply is done in the same manner without power interruption. Since the supplies are paralleled only for a few hundred milliseconds, it is not necessary to dimension the switchboard for the combined short-circuit power of both the normal incoming supply and the generator.

Where equipment has been designed to operate in parallel on a permanent basis, it is not necessary to trip the incoming supply after connection the generator to the load. For this case, however, the switchboard must be designed for the combined short-circuit power of the incoming supply and the generator.

## 4.2 Stand alone operation

Generator sets are often designed to operate independently (isochronous mode).

In such cases the system frequency will be controlled by the engine governor. Overloads exceeding the maximum power output (standby power rating for Diesel engines as described in 2) of the set will cause the system frequency

to decrease and this can be used for initiating load shedding.

The generator voltage regulator will determine the system voltage. Generators can normally operate at a power factor of 0.8 and therefore supply most industrial loads without additional power factor compensation equipment.

## 4.3 Parallel operation with utility supply

In some cases permanent operation of the generator set in parallel with the utility supply is required. Since the utility supply is much stronger it will determine the system frequency and the system voltage.

The governor will therefore be used to control the active power output of the engine, and the voltage regulator will control the reactive power output of the generator.

The generator set must know in which configuration it is operating in order to be able to switch the governor and voltage regulator operation from frequency and voltage control (isochronous operation) to active and reactive power control (parallel operation). Auxiliary contacts from the switchboard are normally used to provide the necessary information to the generator sets.

## 4.4 Parallel operation with other generator sets

In this case generator sets are operated in parallel with other generator sets of approximately the same size. There are three basic schemes used.

a) All generator sets but one have fixed active and reactive power output settings. One generator set is in the isochronous mode and will provide the active and reactive power necessary to keep the system frequency and voltage within the allowable limits. Any synchronizing instructions for frequency or voltage changes will be sent to the generator set in the isochronous mode. Since all power fluctuations will be absorbed only by this generator set, this scheme cannot be easily used where there are large variations in load.

b) All generator sets operate in the droop mode. The active and reactive power is then shared equally among the sets or in proportion to their rated power if sets with different ratings are

used. Variations in load will cause voltage and speed fluctuations due to the droop characteristic which is normally 4% from zero to 100% load. Since synchronizing of the sets with another source can only be done by adjusting the droop setting, this scheme is normally not used when parallel operation with another source is required.

c) All generator sets are interfaced in order to share the active and reactive power. An example of how this is done is shown in **figure 6**. Each engine governor receives the active power set point from the active load dispatcher which also provides frequency regulation.

Similarly each excitation regulator receives the reactive power set point from the reactive power dispatcher which also provides voltage regulation.

This scheme allows for large load variation without changes in frequency or voltage.

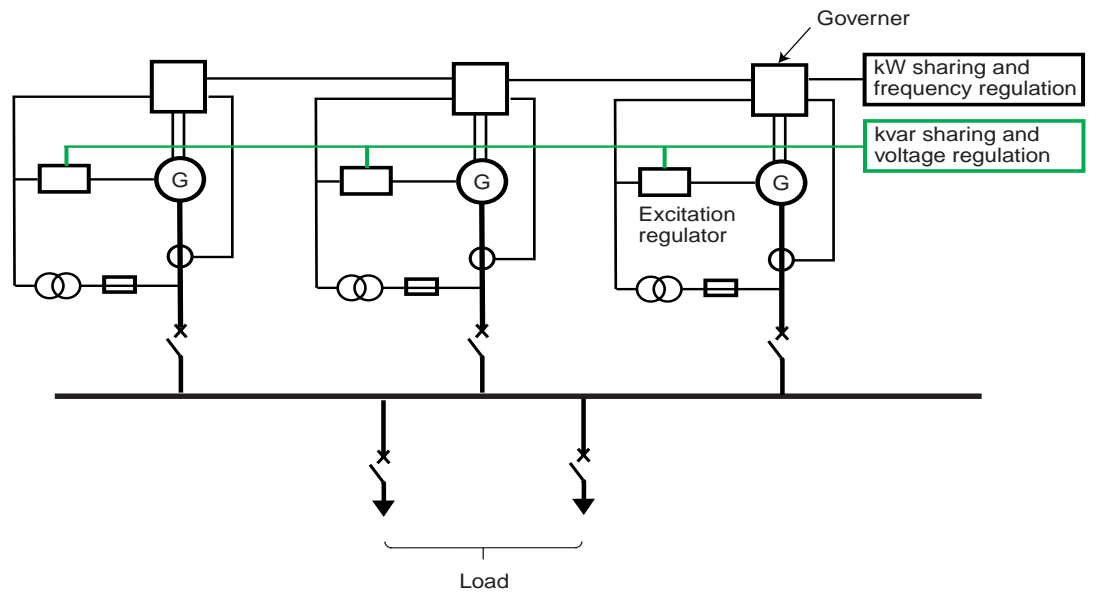

**Fig. 6:** parallel operation using a load dispatcher



# 5 Transfer schemes and synchronization

## 5.1 Automatic transfer on loss of supply

An automatic transfer normally occurs when there is a loss of the normal supply and the load is to be supplied from the back-up supply with a minimum outage time. The transfer is blocked should the reason for the loss of supply be a fault on the busbar. Closing the emergency supply circuit-breaker onto a busbar fault will result in loss of the emergency supply and could result in damage to the equipment.

Two techniques for transferring are generally used, their choice being based on whether or not the plant can accept a brief loss of supply.

### Residual voltage transfer

This is the most commonly used automatic transfer scheme and has the following basic steps:

- trip the incoming breaker to isolate the load from the supply
- start the generator set
- shed any loads which cannot be supplied from the generator set
- close the generator circuit-breaker after the generator set is able to be loaded, and the residual voltage on the busbar is less than 30%.

### Fast transfer

A fast transfer scheme is used when the process cannot accept any power outages.

Such a system requires that the backup supply be permanently available and that the load is transferred to the backup supply before drives have had time to slow down. The time window for such switching is about 150 ms.

In order to avoid the mechanical stresses and large currents due to out-of-phase switching, it is necessary to give the closing order to the emergency supply circuit-breaker such that the voltage generated by the decelerating motors is close to being in phase with the emergency system voltage when the circuit-breaker closes.

Control gear for such transfer systems take into account the closing time of the circuit-breaker in order to anticipate the correct switching moment. If switching does not occur during the 150 ms time window, the fast transfer is blocked and a residual voltage transfer is made including any required load shedding.

## 5.2 Maintenance transfer

After the normal supply has returned, the load should be transferred from the emergency supply back to the normal supply. This is

normally initiated manually as described at the end of section 4.1 above.

## 5.3 Synchronization of generator circuit-breaker

Any time parallel operation of a generator set is required, it is necessary to be able to synchronize it to the system. Synchronization basically consists in adjusting the generator frequency and voltage to values close to the system values. Since the system frequency and voltage can vary within a few percent, it is necessary that both the engine speed and the generator voltage be able to be adjusted for synchronization purposes.

The engine speed and generator voltage are controlled by the governor and voltage regulator. Adjustments in the frequency and voltage are normally achieved by momentarily closing contacts connected to the governor and voltage regulator. When the generator voltage is almost in phase with the system voltage a closing order is given to the generator circuit-breaker.

Synchronization is normally done automatically by means of relays which measure generator and line voltages, frequencies, and phase angles. The relay automatically adjusts the speed and voltage of the generator set and closes the circuit-breaker when the phase angle between the generator and line voltages is sufficiently small. One set of automatic synchronization equipment can be used for several generators by selecting the appropriate voltage transformers and sending the  $\pm$  voltage,  $\pm$  speed as well as the closing order to the selected circuit-breaker.

Manual synchronizing should be provided in all cases, either as a back up to the automatic synchronizing system, or for use in applications where synchronization would only rarely occur. For manual synchronization the operator uses

push buttons to provide the voltage and speed adjustment signals.

A synchroscope will let the operator know when the line and generator voltages are sufficiently in phase to close the circuit-breaker. For manual synchronization use of a synchronism check protection relay is recommended which will

inhibit closing of the circuit-breaker unless all conditions of frequency, voltage, and phase angle have been satisfied.

Synchronization across the generator circuit-breaker is often included as a standard feature in generator set control equipment.

## 5.4 Synchronization of bus-tie, bus-coupler, or utility incoming circuit-breakers

When several generator sets are used, they are often connected to different busbars in order to facilitate maintenance. It is therefore possible at times to have generator sets supplying loads on busbars which are not connected together. In order to have all busbars connected it will be necessary to synchronize groups of generator sets across bus-tie or bus-coupler circuit-breakers.

Specific synchronization equipment is normally required for such applications since the generator set normally allows synchronizing across the generator circuit-breaker only.

A similar situation can occur when plant load is being supplied by generator sets and it is necessary to connect the loads to the utility. Synchronization across the utility circuit-breaker will be necessary.

Synchronization requires voltage and speed adjustments. As described in section 4.4 above, synchronization of a group of generator sets is possible when one set is in the isochronous mode, or when a load dispatcher is used which will change the power output (and therefore

speed) of all sets. When a set is in the isochronous mode, the voltage and speed adjustment signals will be sent to that set and the others will follow according to their droop characteristic. When a load dispatcher is used, the  $\pm$  frequency signal will be sent to the load dispatcher which then sends appropriate signals to the individual governors.

The voltage regulators used in such cases are sometimes connected to the voltage transformer of the busbar to which they are to be synchronized and can therefore adjust their excitation accordingly without receiving a separate  $\pm$  voltage signal.

For both schemes, once the required frequency, voltage, and phase angle have been achieved, the circuit-breaker can be closed. Some manufacturers of load dispatching systems offer adjustment of the voltage in addition to adjustment of the speed. Specifications for synchronization equipment should therefore clearly specify all the functional requirements thereby allowing suppliers to choose the best solution.

## 6 Generator set protection

### 6.1 General protection philosophy

Since generators are a source of electrical power, the overcurrent protection relays should be connected to current transformers on the neutral side of the stator windings in order to cover faults occurring in the windings.

Additional protection relays are required at the generator circuit-breaker only for applications where generator sets will be operating in parallel with other generator sets or with the utility, and will pick up faults on the line side of the generator. The current transformers for these

protection relays are installed at the generator circuit-breaker in order to cover the whole connection to the generator.

Reverse active and reverse reactive power relays are normally connected to current transformers on the neutral side of the generator as shown in **figure 7**. They can also be connected to the current transformers associated with the circuit-breaker. The location will depend on the split of works as described in chapter 9.1.

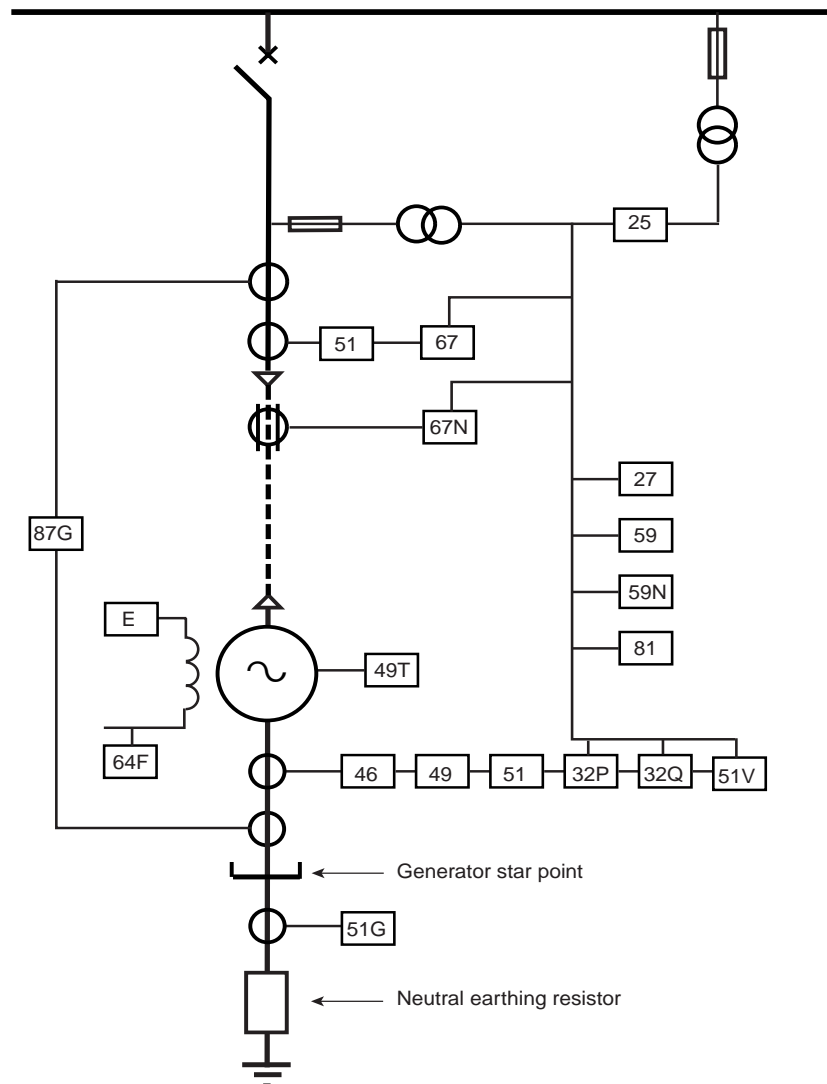

**Fig. 7:** recommended generator protection

## 6.2 Electrical protection

The recommended protection functions are shown in figure 7. Function reference numbers are the following:

■ protection functions connected to generator neutral current transformers:

- 32P : reverse active power
- 32Q : reverse reactive power serving as loss of field (for generators above 1 MVA)
- 46 : negative sequence (for generators above 1 MVA)
- 49 : thermal image
- 51 : overcurrent
- 51G : earth fault
- 51V : voltage restrained overcurrent
- 87G : generator differential protection (for generators above 2 MVA)

(Note: 46,49, 32P and 32Q can also be connected to the line-side current transformers)

■ protection functions connected to voltage transformers:

- 25 : synchronism-check (for parallel operation only)
- 27 : undervoltage

- 59 : overvoltage
- 81 : overfrequency and underfrequency
- protection functions connected to line-side current transformers (for parallel operation only):
- 67 : directional overcurrent (not required if 87G is used)
- 67N : directional earth fault (on core balance CT for better sensitivity)
- generator mechanical protection functions connected to sensors
- 49T : stator temperature (recommended for generators above 2 MVA)
- 49T : bearing temperature (recommended for generators above 8 MVA)
- 64F : rotor earth fault protection

The following table ( see **fig. 8** ) gives typical settings for each protection function, and what action should be taken. This information should be verified with the generator set manufacturer for each application. A general shutdown means tripping and locking out the generator circuit-breaker, switching off the excitation, and closing the fuel supply to the engine.

Function	Typical setting	Action
27	0.75 Un, T ≈ 3 s T > longest time of 51, 51V, 67	General shut-down
32P	1-5 % for turbine, 5-20 % for Diesel, T = 2 s	General shut-down
32Q	0.3 Sn, T = 2 s	General shut-down
46	0.15 In, inverse time curve	General shut-down
49	80% thermal capacity = alarm 120% thermal capacity = trip time constant 20 min operating time constant 40 min standstill	Trip breaker only, overload may be temporary
51	1.5 In, 2 s	General shut-down
51G	10 A, 1 s	General shut-down
51V	1.5 In, T= 2.5 s	General shut-down
59	1.1 Un, 2 s	General shut-down
81	Overfrequency: 1.05 Fn, 2 s Underfrequency: 0.95 Fn, 2 s	General shut-down
87G	5 % In	General shut-down
67	In, 0.5 s	General shut-down
67N	Is0 ≈ 10 % of earth-fault current, 0.5 s	General shut-down
25	Frequency < ±1 Hz, Voltage < ±5 %, Phase angle <10°	Inhibit closing during synchronization
49T	120 °C	Trip breaker only, overload may be temporary
64F	10 A, 0.1 s	General shut-down
Mechanical protection		General shut-down without lockout

**Fig. 8:** recommended relay settings and action

### Particularities of generator short-circuit currents

As shown in the above table, it is the duty of the generator circuit-breaker to effectively isolate the generator from the network. Due to the low values of transient and permanent short-circuit currents, care must be taken in the choice and setting of the protection relays. In addition, in order to reduce losses in the generator, generator stator resistance is normally kept low by the manufacturers. This will result in high X/R ratios which cause generator short-circuit currents to have a d.c. component with a long time constant.

The IEC 60056 defines test conditions for medium-voltage circuit-breakers. The test conditions are based on short-circuit currents having a d.c. component with a time constant of 45 ms. Since generator short-circuit currents may have time constants greatly exceeding this value, the circuit-breaker manufacturer must

choose the adequate circuit-breaker and demonstrate that it is suitable for the application.

### Possible delaying of circuit-breakers

In addition to the significant d.c. component, the generator short-circuit current can also have zero-axis crossings which occur only after several periods resulting in unsuccessful interruption of the short-circuit current as shown in **figure 9**. This is due to the alternating component of the short-circuit current decreasing much more rapidly than the d.c. component.

Since medium-voltage circuit-breakers require natural zero-axis crossing of the short-circuit current for successful interruption, it may be necessary to delay operation of the circuit-breaker until such time as zero-axis crossings do occur. Such delays must be taken into account in the protection relay coordination study and can also reduce the system stability.

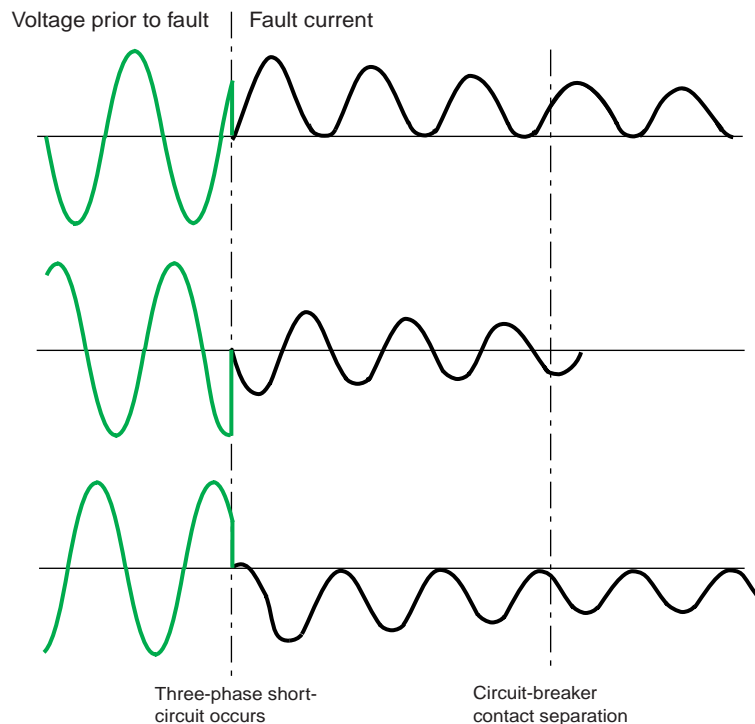

**Fig. 9:** generator short-circuit current with delayed zero-axis crossing on phases 1 & 3 (phase 2 interrupts correctly since short-circuit occurs here when voltage is at its peak on this phase, consequently short-circuit current, with  $90^\circ$  lag, starts at zero, without dc component).

## 6.3 Machine protection

The generator set will have mechanical protection related to the prime mover. This typically includes oil level, oil temperature, water level, water temperature, and exhaust temperature. Often the rotor earth fault protection is provided as an

integral part of the set since it requires injection of a d.c. current between the rotor and earth. A signal should be sent to trip the generator circuit-breaker without lockout should mechanical protection require a shutdown.

# 7 Connection of generators to electrical distribution network

## 7.1 Connection to generator circuit-breaker

Generators have a limited capacity to withstand voltage impulses. When it is possible to operate medium-voltage generators in parallel with the utility supply it is recommended to provide surge protection at the generator incoming terminals.

This normally consists in connecting surge capacitors (typical value of 0.3  $\mu\text{F}$ ) and lightning arresters between phase and ground in the generator line-connection box. Such precautions are not required for low-voltage generators since they are shielded from impulses by the upstream step-down transformers.

When the generator line-connection box has been designed for surge protection devices, it is recommended to install the generator voltage

transformers in it as well. The voltage transformer can however be easily integrated into the downstream switchgear should the generator connection box not be sufficiently large.

Current transformers should be installed in the generator neutral point connection box. When generator differential protection excludes the generator line-side connection cable (or busduct), current transformers are installed in the generator line-side connection box. When generator differential protection includes the line-side connection cable (or busduct), the current transformers are installed in the downstream switchboard.

## 7.2 Connection of generator neutral point

### Stand-alone generator set

A generator which does not operate in parallel with any other source should be earthed by means of a resistor connected between the star point and earth. The generator manufacturer can provide a damage curve showing the allowable earth fault current as a function of time.

The earthing resistor and protection relay settings should be determined based on this curve. In general earth fault current for medium voltage generators should be kept less than 30 A in order to prevent any damage to the stator itself.

### Operation in parallel with utility or other sets

When several sets operate in parallel or together with the utility it is difficult to keep the earth fault current within acceptable limits.

The maximum earth fault current will be the sum of the earth fault current in all sources and this can easily exceed the value given on the damage curve mentioned previously. Reducing this maximum value by limiting the earth fault current to a small value for each source will

result in earth fault current being too small when only one or two sets are in operation. It is recommended to keep the star points unearthed and to provide earthing transformers for each busbar as shown in figure 5.

When busbars are operated with the bus-tie circuit-breakers closed, only one earthing transformer should be connected. When the bus-tie circuit-breakers are open, one earthing transformer should be connected to each busbar section. This will permit a constant value of earth fault current independent of the type and number of sources used, and greatly simplify the earth-fault protection system.

Should a fault occur in the earthing transformer, it should be tripped but the generator sets connected to the busbar should be kept in operation. There is no immediate danger to the sets when operated on a temporarily unearthed system.

The maintenance personnel should determine the subsequent operation of the system.

## 8 Load shedding

Load shedding is often required in order to ensure that the essential parts of the process are supplied with electrical energy during high load conditions, or when system disturbances occur. Since the only additional energy available in an electrical distribution system is the spinning reserve of rotating machinery, sites supplied by generator sets only have very limited reserves and are very susceptible to instability due to disturbances such as faults in the electrical distribution system.

Three different scenarios requiring load shedding can be considered:

- gradual increase in load
- loss of a generator
- electrical faults

To ensure a reliable electrical supply to essential process equipment, each of the above cases must be studied to ensure that correct load shedding is implemented. In general the load shedding system must continually check the balance between the load and the available power in order to switch off non-essential loads required to maintain system stability. The effects and remedial measures for each scenario are described below.

### **Gradual increase in load**

It is possible during certain periods that the total load exceeds the rated power of the generator sets. Due to the overload capacity of 10% for one hour normally provided with production sets, and the gradual increase of load, the load shedding system can perform all calculations in real time and generate load shedding signals to trip non-essential loads. The operators can switch the non-essential loads back on after the peak period has passed.

### **Loss of a generator**

The loss of a generator can suddenly result in the available power being much less than the load. It is necessary to shed non-essential loads immediately in order to ensure the stability of the electrical distribution system. If this is not done, other generators will be tripped due to overload, undervoltage or underfrequency and the whole electrical supply could be lost. The load shedding system normally prepares load shedding tables based on the scenario of loss of a generator so that when such an incident does occur, it can immediately send the trip signals. Load shedding can be achieved in less than 200 ms which is normally sufficient to prevent loss of system stability which could lead to a complete loss of the distribution system.

### **Electrical faults**

When an electrical fault occurs, protection relays will detect the fault and circuit-breakers will isolate the faulty equipment. During the time required to eliminate the fault, the voltage at the fault can be very close to zero which can cause all the motors in the plant to decelerate. After the fault has been cleared, the motors will draw more current since they must be brought back up to speed. This can further reduce the voltage in certain portions of the network causing a snowball effect which can lead to tripping of circuit-breakers supplying healthy portions of the distribution system. In order to prevent such a loss of stability, load shedding based on voltage and/or frequency should be implemented. In order to determine how much load should be shed, and at what value of voltage or frequency, a stability study of the electrical distribution system is required. This study will modelize the dynamic response of the system to disturbances and enable the load shedding strategy to be prepared.



## 9 Interfacing generator with electrical distribution system

### 9.1 Typical split of supply between generator set manufacturer and switchgear manufacturer

It is very common for the generator set to be supplied by a different company than the company which supplied the switchgear to which it is connected. It is therefore beneficial for all parties to reduce the interfaces between the equipment to a minimum. A coordination meeting between the switchgear and generator set suppliers should be held prior to any detailed engineering. During this meeting the split of works, interfaces, information to be exchanged, and schedule should be determined. Correct definition should allow each supplier to do engineering, manufacturing, erection, testing, and equipment commissioning at site in an independent manner. System commissioning can then be done by both parties after all interfaces have been made. Keeping interfaces simple also enables each manufacturer's responsibility to be clearly defined.

Each supplier should be responsible for the installation of all equipment in his supply. Installing components supplied by one manufacturer in equipment supplied by the other should be avoided. A typical example is the generator excitation module which should be installed in a panel supplied by the generator manufacturer, and not in the switchgear.

When generators can operate in parallel it is necessary to install protection gear in the switchgear for eliminating faults occurring

between the generator and the switchgear. This protection gear should be in the switchgear manufacturer's scope. Protection gear for the generator itself can be supplied either by the generator set manufacturer, or the switchgear manufacturer. Either solution is acceptable, and both require exchanges of information since equipment data for setting the relays will come from the generator set manufacturer, whereas information for the integration into the overall plant protection scheme will come from the switchgear manufacturer.

When generator differential protection is used, it is quite common for the line-side current transformer to be installed in the switchgear and the neutral side current transformer to be installed in the generator neutral connection box. The supplier of the differential protection relay should define the characteristics of the line and neutral current transformers and each manufacturer should supply the current transformer to be installed in his equipment. It is not necessary nor for reasons mentioned previously is it desirable that one manufacturer supply the current transformers to be installed in the other manufacturer's equipment.

The auxiliary supplies for the generator set should be independent of those of the switchgear. The generator set should have its own battery backed d.c. supply.

### 9.2 Information to be exchanged

The information to be exchanged between the generator set and the switchgear should be kept to a minimum. The information should be exchanged by means of potential-free contacts, and 4-20 mA analog signals.

The meaning of each signal (eg. close to actuate, closed for circuit-breaker open position) and the minimum duration of each signal (eg. closing signal duration: 500 ms) should be clearly stated on the interface documentation.

Fail-safe circuits should be used. Such circuits use contacts which close to actuate, and normally open contacts which are maintained closed for authorization. These circuits are called fail-safe since a broken wire will not result in undesired actuation or authorization.

The voltage to be applied to the potential-free contacts, and the contact loading should also be stated in order to ensure that the correct devices have been chosen.

This type of interfacing enables each supplier to design, manufacture, and test his equipment independently. Data exchanged directly via serial links should be avoided since this is much more difficult to define, commission, and trouble shoot. The amount of information to be exchanged does not justify this type of interface.

The information typically exchanged is:

- information from generator set:
  - ready to start (information)
  - ready for loading (information)
  - trip on fault (order)

- general alarm (information)
- generator voltage (from voltage transformer, for synchronizing)
- information to generator set:
  - start (order)
  - circuit-breaker on/off status (information)
  - busbar voltage (from voltage transformer, for synchronizing)
  - stand-alone operation, or parallel operation (information)
  - type of fault (information)

### 9.3 Integration of generator set into electrical distribution supervisory system

In order to prevent loss of supply preventative maintenance is required.

Preventative maintenance can be very effective provided that the information needed to trigger it is available, thus ensuring that the maintenance will be made prior to the fault occurring.

The required information can be collected and displayed to the operator by a power management system. Such information can include running hours of generator sets, temperature measurements of generator

windings or bearings, and power consumption of particular loads. The power management system can also be used to supply the information required by the load shedding system described in section 8 above to perform the power balance calculations.

The operator can also reconfigure the power distribution system from the power management system console. This is very convenient should an incident have occurred and switching be required to reenergize equipment.

# 10 Installation and maintenance of generator sets

The installation of generator sets requires close cooperation among several disciplines such as electrical, construction, process, and mechanical.

The following information should be considered when designing the installation of the sets.

## 10.1 Location

The location should be chosen close to the load center to reduce voltage drop and losses in the connections. Due to the relatively large size of the equipment, adequate space must be allowed for the transportation to and from the location. The building housing the equipment must have adequate space to allow maintenance including overhauling, and be provided with the necessary overhead cranes. The generator set manufacturer should provide all information

concerning space and access requirements on civil works guide drawings. In many locations noise emission will be a problem. The solution consists in sound proofing the generator set, the building, or a combination of both. Sound proofing will have a significant impact on cost and therefore must be defined prior to placing an order for equipment. Care must also be taken to avoid noise transmission via the generator set base.

## 10.2 Air intake and exhaust

In the definition of the rated power of generator sets, the length and configuration of the air intake ducts and the exhaust piping is important. In certain cases generator sets will be located in areas where long ducting and piping is required, and this is to be taken into account in the definition of the rated power of the engine.

Care must also be taken to ensure that the air intake is remote from the exhaust.

Generator sets used for emergency power must be able to operate in all site conditions. In desert areas this can include sand storms. Special sand filters are required at the air intake and can increase the foot print and cost of the generator set.

## 10.3 Compliance with local regulations

In many countries there are local regulations that must be met. In addition to requirements related to emissions, environmental considerations often dictate the design of the fuel system. This can include the maximum capacity of day tanks and the type of buried storage tanks (double walled, etc.).

Local regulations must also be respected for the fire detection and protection equipment. Fire detection should be installed in all locations where generator sets are located. Automatic fire protection equipment should also be provided where possible.

Fire protection is normally achieved by flooding the building with inert gas. This type of system requires automatic shutting of ventilation openings, air intake openings, and doors.

Local regulations cover many aspects such as the number and location of warning signs, the location of the fire control panel, and the type of inert gas which can be used.

The assistance of a local company familiar with such regulations to get all required approvals is very useful and often indispensable.

## 10.4 Special tools and spare parts

Generator sets require periodic maintenance and also overhauls after a certain number of years of operation. Special tools are normally required for periodic maintenance, and additional special tools are required for overhauls. The definition and supply of tools should be made with the generator set manufacturer based on the type of

maintenance to be performed. The list of special tools should be checked with the maintenance manuals in order to ensure that all have been provided. Spare parts for the first overhaul should be provided in addition to those required for normal operation.

# 11 Conclusion

Engine driven alternating current generating sets are often installed in industrial sites and commercial buildings as main sources of electrical energy or for supplying essential loads in case of loss of the utility supply.

A good understanding of the electrical and mechanical characteristics of the generator sets and the standards which define them is important for correct choice of the equipment.

The integration of the generator sets into the electrical distribution system has a large impact on most of the electrical equipment. The generators will contribute to the maximum available short-circuit current which must be taken into account in dimensioning the switchgear. The plant electrical protection

system must take into account the particularities of generators in order to ensure correct protection of persons and equipment but at the same time avoid nuisance tripping which results in loss of the supply of electrical power. The control system must enable the electrical distribution system to be operated in different configurations required for ensuring a reliable supply of power.

The engineer responsible for the correct design of the complete electrical distribution system is confronted with many different types of problems to solve. Being aware of the problems and knowing typical solutions to them is the first step in ensuring that the final electrical distribution system will meet the requirements of the application.

# Bibliography

## Standards

- IEC 60056: High voltage alternating current circuit breakers.
- IEC 60255: Electrical relays.
- IEC 60298: A.C. metal enclosed switchgear and controlgear for rated voltages above 1 kV and up to and including 52 kV.
- IEC 60439-1: Low-voltage switchgear and controlgear assemblies.
- ISO 3046: Reciprocating internal combustion engines.
- ISO 8528: Reciprocating internal combustion engine driven alternating current generating sets.

## Schneider Electric Cahiers Techniques

- Electrical disturbances in LV  
Cahier Technique no. 141  
R. CALVAS
- Active harmonic conditioners and unity power factor rectifiers  
Cahier Technique no. 183  
E. BETTEGA, J-N. FIORINA
- Disjoncteurs au SF6 Fluarc et protection des moteurs MT  
Cahier Technique n° 143  
J. HENNEBERT et D. GIBBSO



**Schneider Electric**

Direction Scientifique et Technique,  
Service Communication Technique  
F-38050 Grenoble cedex 9  
Fax : (33) 04 76 57 98 60

Real.: AK  
Edition: Schneider Electric  
Printing: Imprimerie du Pont de Claix - Claix - France - 1000  
- 100 FF -