

Cahier technique no. 172

Earthing systems in LV

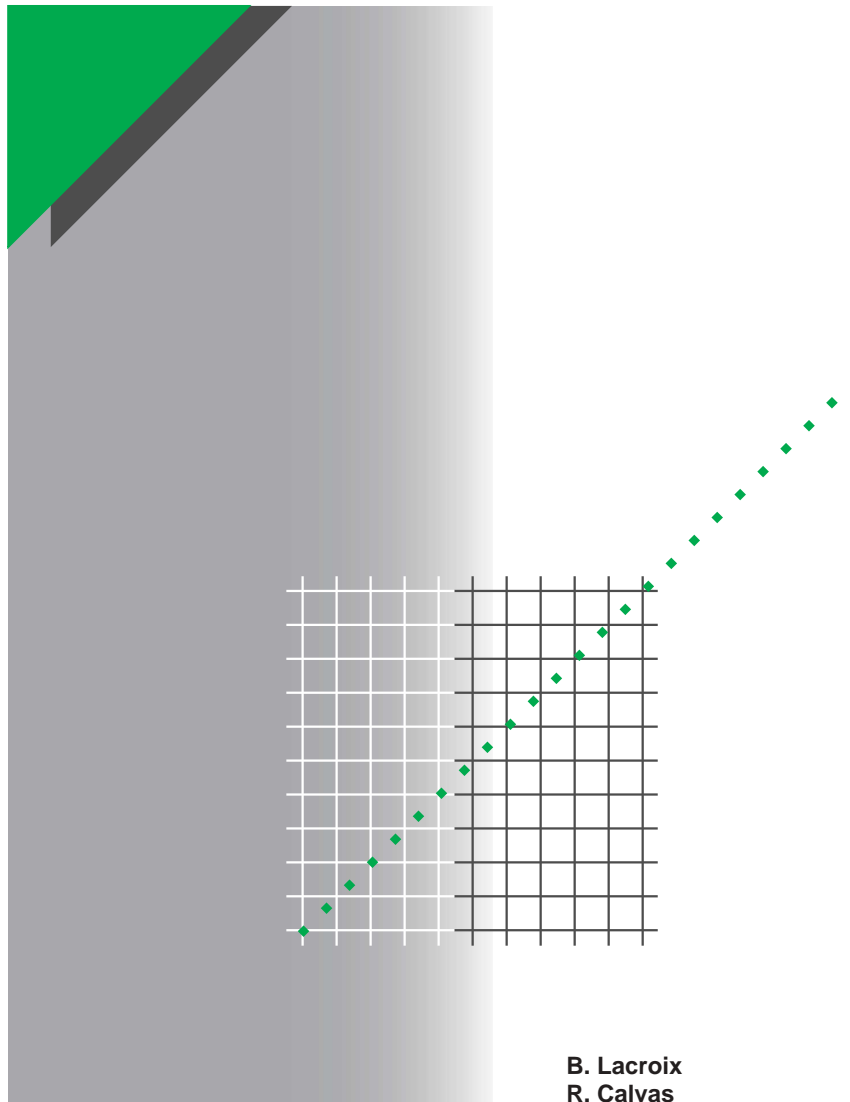

- Merlin Gerin
- Modicon
- Square D
- Telemecanique

B. Lacroix
R. Calvas

"Cahiers Techniques" is a collection of documents intended for engineers and technicians, people in the industry who are looking for more in-depth information in order to complement that given in product catalogues.

Furthermore, these "Cahiers Techniques" are often considered as helpful "tools" for training courses.

They provide knowledge on new technical and technological developments in the electrotechnical field and electronics. They also provide better understanding of various phenomena observed in electrical installations, systems and equipments.

Each "Cahier Technique" provides an in-depth study of a precise subject in the fields of electrical networks, protection devices, monitoring and control and industrial automation systems.

The latest publications can be downloaded from the Schneider Electric internet web site.

Code: <http://www.schneider-electric.com>

Section: **Experts' place**

Please contact your Schneider Electric representative if you want either a "Cahier Technique" or the list of available titles.

The "Cahiers Techniques" collection is part of the Schneider Electric's "Collection technique".

Foreword

The author disclaims all responsibility subsequent to incorrect use of information or diagrams reproduced in this document, and cannot be held responsible for any errors or oversights, or for the consequences of using information and diagrams contained in this document.

Reproduction of all or part of a "Cahier Technique" is authorised with the prior consent of the Scientific and Technical Division. The statement "Extracted from Schneider Electric "Cahier Technique" no." (please specify) is compulsory.

no. 172

Earthing systems in LV



Bernard LACROIX

An ESPCI 74 graduate engineer (from the Ecole Supérieure de Physique et Chimie Industrielle de Paris), he then worked 5 years for Jeumont Schneider, where his activities included development of the TGV chopper.

After joining Merlin Gerin in 1981, he was then in turn Sales Engineer for UPS and sales manager for protection of persons.

Since 1991 he is in charge of prescription for LV power distribution.



Roland CALVAS

An ENSERG 1964 graduate engineer (from the Ecole Nationale Supérieure d'Electronique et Radioélectricité de Grenoble) and an Institut d'Administration des Entreprises graduate, he joined Merlin Gerin in 1966.

During his professional career, he was sales manager, then marketing manager in the field of equipment for protection of persons, and finally in charge of technical communication for Schneider Electric, until retirement early 1999.

Lexicon

Electric Shock: Application of a voltage between two parts of the body

Electrocution: Electric Shock resulting in death

EMC: Electro Magnetic Compatibility

I Δ n: Operating threshold of a RCD

IMD: Insulation Monitoring Device

GFLD: Insulation Fault Location Device

MV/HV: Medium Voltage: 1 to 35 kV as in CENELEC (circular of the 27.07.92)

High Voltage: 1 to 50 kV as in french standard (14.11.88)

RCD: Residual Current Device

SCPD: Short-Circuit Protection Device (circuit-breakers or fuses)

STD: Short Time Delay protection (protection against short-circuit overcurrents by circuit-breaker with rapid trip release)

TBM: Technical Building Management

TEM: Technical Electrical Power Distribution Management

U_L: Conventional limit voltage (maximum acceptable contact voltage) known as the "safety" voltage

Earthing systems in LV

This "Cahier Technique" reviews the hazards that insulation faults represent for safety of persons and property. It emphasises the influence of earthing systems and the availability of electrical power.

It presents the three earthing systems defined in standard IEC 60364 and used to varying degrees in all countries.

Each earthing system is looked at in terms of dependability (safety, maintainability and availability).

None of the earthing systems is basically bad. They all ensure safety of persons. Each system has its own advantages and disadvantages and the user must therefore be guided according to his needs, with the exception, however, of prescription or of standard or legislative bans.

Readers interested in different practices of various countries and in the evolution of earthing systems should read "Cahier Technique" no. 173.

Contents

1 Introduction	1.1 Evolution of needs	p. 4
	1.2 Causes of insulation faults	p. 4
	1.3 Hazards linked to insulation faults	p. 5
2 Earthing systems and protection of persons		p. 8
	2.1 TN system	p. 9
	2.2 TT system	p. 10
	2.3 IT system	p. 11
3 Earthing systems confronted with fire and electrical power unavailability hazards	3.1 Fire	p. 15
	3.2 Electrical power unavailability	p. 15
4 Influences of MV on BV, according to the earthing systems	4.1 Lightning	p. 17
	4.2 Operating overvoltages	p. 17
	4.3 MV-frame disruptive breakdown of the transformer	p. 18
	4.4 MV-LV disruptive breakdown inside the transformer	p. 19
5 Switchgear linked to choice of earthing system	5.1 TN system	p. 20
	5.2 TT system	p. 21
	5.3 IT system	p. 21
	5.4 Neutral protection according to the earthing system	p. 23
6 Choice of earthing system and conclusion	6.1 Methods for choosing the earthing system	p. 25
	6.2 Conclusion	p. 25
Bibliography		p. 26

1 Introduction

1.1 Evolution of needs

Today the 3 earthing systems such as defined in IEC 60364 and French standard NF C 15-100, are:

- exposed-conductive parts connected to neutral -TN-;
- earthed neutral -TT-;
- unearthed (or impedance-earthed) neutral -IT-.

The purpose of these three systems is identical as regards protection of persons and property: mastery of insulation fault effects. They are considered to be equivalent with respect to safety of persons against indirect contacts. However, the same is not necessarily true for dependability of the LV electrical installation with respect to:

- electrical power availability;
- installation maintenance.

These quantities, which can be calculated, are subjected to increasingly exacting requirements in factories and tertiary buildings. Moreover, the control and monitoring systems of buildings -TBM- and electrical power distribution management systems -TEM- play an increasingly important role in management and dependability.

This evolution in dependability requirements therefore affects the choice of earthing system.

It should be borne in mind that the concern with continuity of service (keeping a sound network in public distribution by disconnecting consumers with insulation faults) played a role when earthing systems first emerged.

1.2 Causes of insulation faults

In order to ensure protection of persons and continuity of service, conductors and live parts of electrical installations are «insulated» from the frames connected to the earth.

Insulation is achieved by:

- use of insulating materials;
- distancing, which calls for clearances in gases (e.g. in air) and creepage distances (concerning switchgear, e.g. an insulator flash over path).

Insulation is characterised by specified voltages which, in accordance with standards, are applied to new products and equipment:

- insulating voltage (highest network voltage);
- lightning impulse withstand voltage (1.2; 50 ms wave);
- power frequency withstand voltage ($2 U + 1,000 \text{ V/1mn}$).

Example for a LV PRISMA type switchboard:

- insulating voltage: 1,000 V;
- impulse voltage: 12 kV.

When a new installation is commissioned, produced as per proper practices with products manufactured as in standards, the risk of insulation faults is extremely small; as the installation ages, however, this risk increases.

In point of fact, the installation is subject to various aggressions which give rise to insulation faults, for example:

- during installation:
 - mechanical damage to a cable insulator;
- during operation:
 - conductive dust,
 - thermal ageing of insulators due to excessive temperature caused by:
 - climate,
 - too many cables in a duct,
 - a poorly ventilated cubicle,
 - harmonics,
 - overcurrents, etc,
 - the electrodynamic forces developed during a short-circuit which may damage a cable or reduce a clearance,
 - the operating and lightning overvoltages,
 - the 50 Hz return overvoltages, resulting from an insulation fault in MV.

It is normally a combination of these primary causes which results in the insulation fault. The latter is:

- either of differential mode (between live conductors) and becomes a short-circuit;
- or of common mode (between live conductors and frame or earth), a fault current -said to be common mode or zero sequence (MV)- then flows in the protective conductor (PE) and/or in the earth.

LV earthing systems are mainly concerned by common mode faults which mainly occur in loads and cables.

1.3 Hazards linked to insulation faults

An insulation fault, irrespective of its cause, presents hazards for:

- human life;
 - preservation of property;
 - availability of electrical power;
- the above all depending on dependability.

Electric Shock of persons

A person (or animal) subjected to an electrical voltage is electrified. According to the gravity of the Electric Shock, this person may experience:

- discomfort;
- a muscular contraction;
- a burn;
- cardiac arrest (this is Electrocutation) (see [fig. 1](#)).

Since protection of persons against the dangerous effects of electric current takes

priority, Electric Shock is thus the first hazard to be considered.

The current strength I -in value and time-, passing through the human body (in particular the heart) is the dangerous aspect. In LV, the impedance value of the body (an important aspect of which is skin resistance) virtually changes only according to environment (dry and wet premises and damp premises).

In each case, a safety voltage (maximum acceptable contact voltage for at least 5 s) has been defined: it is known as the conventional limit voltage U_L in IEC 60479.

IEC 60364 paragraph 413.1.1.1 (and NF C 15-100) state that if there is a risk of contact voltage U_c exceeding voltage U_L , the application time of the fault voltage must be limited by the use of protection devices (see [fig. 2](#)).

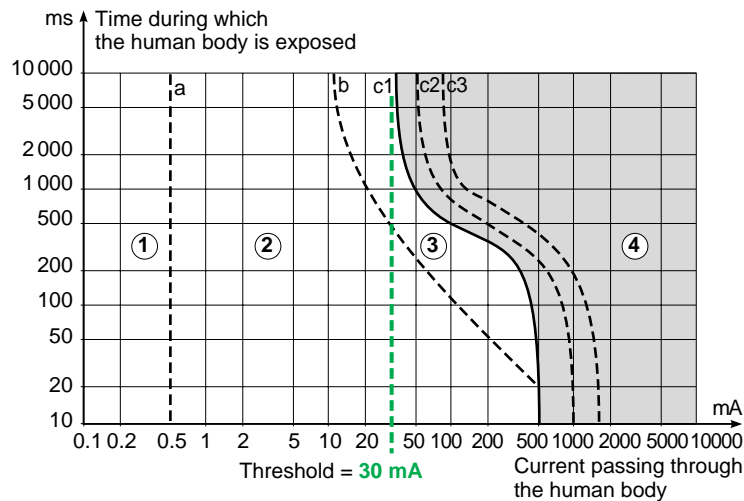

- Zone 1: perception
- Zone 2: considerable discomfort
- Zone 3: muscular contractions
- Zone 4: risk of ventricular fibrillation (cardiac arrest)
- c2: likelihood < 5 %
- c3: likelihood ≥ 50 %

Fig. 1 : time/current zones of ac effects (15 Hz to 100 Hz) on persons as in IEC 60479-1.

- Dry or humid premises and places: $U_L \leq 50$ V

Presumed contact voltage (V)		< 50	50	75	90	120	150	220	280	350	500
Maximum breaking time of the protection device (s)	ac	5	5	0.60	0.45	0.34	0.27	0.17	0.12	0.08	0.04
	dc	5	5	5	5	5	1	0.40	0.30	0.20	0.10

- Wet premises and places: $U_L \leq 25$ V

Presumed contact voltage (V)		25	50	75	90	110	150	220	280
Maximum breaking time of the protection device (s)	ac	5	0.48	0.30	0.25	0.18	0.10	0.05	0.02
	dc	5	5	2	0.80	0.50	0.25	0.06	0.02

Fig. 2 : maximum time for maintenance of contact voltage as in standard IEC 60364.

Fire

This hazard, when it occurs, can have dramatic consequences for both persons and property. A large number of fires are caused by important and localised temperature rises or an electric arc generated by an insulation fault. The hazard increases as the fault current rises, and also depends on the risk of fire or explosion occurring in the premises.

Unavailability of electrical power

It is increasingly vital to master this hazard. In actual fact if the faulty part is automatically disconnected to eliminate the fault, the result is:

- a risk for persons, for example:
 - sudden absence of lighting,
 - placing out of operation of equipment required for safety purposes;

- an economic risk due to production loss. This risk must be mastered in particular in process industries, which are lengthy and costly to restart.

Moreover, if the fault current is high:

- damage, in the installation or the loads, may be considerable and increase repair costs and times;
- circulation of high fault currents in the common mode (between network and earth) may also disturb sensitive equipment, in particular if these are part of a "low current" system geographically distributed with galvanic links.

Finally, on de-energising, the occurrence of overvoltages and/or electromagnetic radiation phenomena may lead to malfunctioning or even damage of sensitive equipment.

Direct and indirect contacts

Before beginning to study the earthing systems, a review of Electric Shock by direct and indirect contacts will certainly be useful.

■ Direct contact and protection measures

This is accidental contact of persons with a live conductor (phase or neutral) or a normally live conductive element (see **fig. 3a**).

In cases where the risk is very great, the common solution consists in distributing electricity using a non-dangerous voltage, i.e. less than or equal to safety voltage. This is safety by extra-low voltage (SELV or PELV).

In LV (230/400 V), protection measures consist in placing these live parts out of reach or in insulating them by means of insulators, enclosures or barriers. A complementary measure against direct contacts consists in using instantaneous ≤ 30 mA High Sensitivity Residual Current Devices known as HS-RCDs.

Treatment of protection against direct contacts is completely independent from the earthing system, but this measure is necessary in all

circuit supply cases where implementation of the earthing system downstream is not mastered. Consequently, some countries make this measure a requirement:

- for sockets of rating ≤ 32 A,
- in some types of installations (temporary, worksite, etc.).

■ Indirect contact, protection and prevention measures

Contact of a person with accidentally energised metal frames is known as indirect contact (see **fig. 3b**).

This accidental energising is the result of an insulation fault. A fault current flows and creates a potential rise between the frame and the earth, thus causing a fault voltage to appear which is dangerous if it exceeds voltage UL.

As regards this hazard, the installation standards (IEC 364 at international level) have given official status to three earthing systems and defined the corresponding installation and protection rules.

The protection measures against indirect contacts are based on three basic principles:

- earthing of the frames of loads and electrical equipment to prevent an insulation fault representing a risk equivalent of a direct contact;

□ equipotentiality of simultaneously accessible frames

Interconnection of these frames considerably helps to reduce contact voltage. It is performed by the protective conductor (PE) which connects

a) direct contact

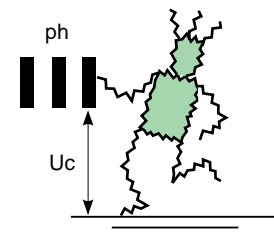

b) indirect contact

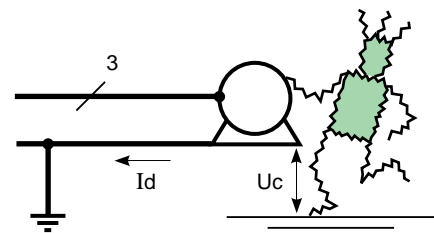

Fig. 3 : direct and indirect contacts.

the frames of electrical equipment for entire buildings, completed if required by additional equipotential links (see **fig. 4**).

Reminder: equipotentiality cannot be complete in all points (in particular in single level premises). Consequently, for the study of earthing systems and their associated protection devices, the hypothesis chosen by standard makers $U_c = U_d$ is applied since U_c is at the most equal to U_d .

- U_d = "fault" voltage, with respect to the deep earth, of the frame of an electrical device with an insulation fault,

- U_c = contact voltage depending on the potential U_c and the potential reference of the person exposed to the hazard, generally the ground;

□ **managing the electrical hazard**

- this management is optimised **by prevention**. For example, by measuring insulation of a device before energising it, or by fault prediction based on live monitoring of insulation evolution of an unearthed installation (IT system),

- if an insulation fault occurs, generating a dangerous fault voltage, it must be eliminated by automatically disconnecting the part of the installation where this fault occurred. How the hazard is removed then depends on the earthing system.

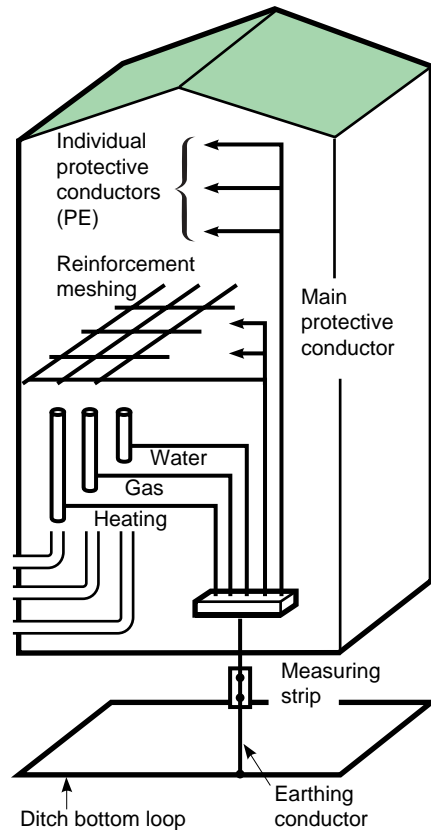

Fig. 4 : equipotentiality in a building.

2 Earthing systems and protection of persons

This section defines the Electric Shock and Electrocutation hazards for the various earthing systems, such as specified by the International Electrotechnical Committee in standard IEC 60364.

The LV earthing system characterises the earthing mode of the secondary of the MV/LV transformer and the means of earthing the installation frames.

Identification of the system types is thus defined by means of 2 letters:

- the first one for transformer neutral connection (2 possibilities):
 - T for "connected" to the earth,
 - I for "isolated" from the earth;
- the second one for the type of application frame connection (2 possibilities):
 - T for "directly connected" to the earth,
 - N for "connected to the neutral" at the origin of the installation, which is connected to the earth (see [fig. 5](#)).

Combination of these two letters gives three possible configurations:

- TT: transformer neutral earthed, and frame earthed,
- TN: transformer neutral earthed, frame connected to neutral,
- IT: unearthed transformer neutral, earthed frame.

Note 1:

The TN system, as in IEC 60364 includes several sub-systems:

- TN-C; if the N and PE neutral conductors are one and the same (PEN);
- TN-S; if the N and PE neutral conductors are separate;
- TN-C-S: use of a TN-S downstream from a TN-C (the opposite is forbidden).

Note that the TN-S is compulsory for networks with conductors of a cross-section $\leq 10 \text{ mm}^2 \text{ Cu}$.

Note 2:

Each earthing system can be applied to an entire LV electrical installation; however several earthing systems may be included in the same installation, see [figure 6](#) as an example.

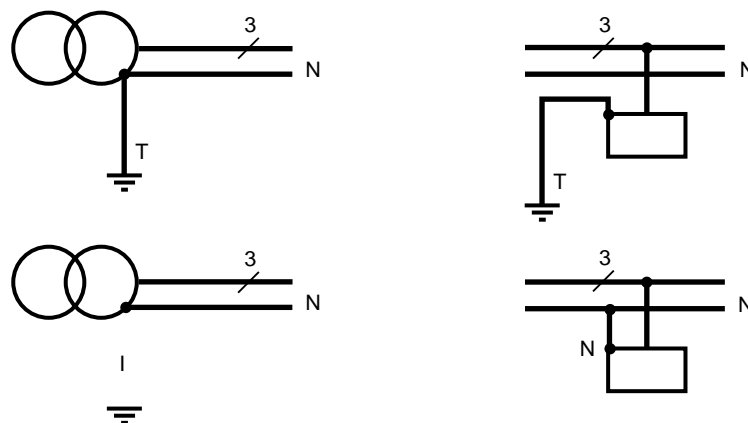

Fig. 5 : connection mode of the neutral at the origin of the installation and of the frames of the electrical loads.

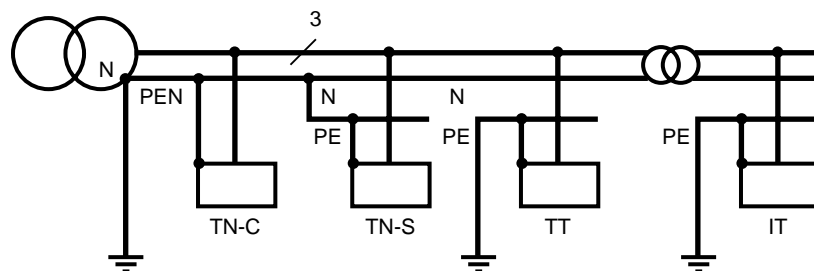

Fig. 6 : example of the various earthing systems included in the same installation.

Note 3:

In France, as in standard NF C 13-100 concerning delivery substations, in order to prevent hazards originating in MV, the LV earthing system is expressed by an additional

letter according to interconnection of the various earth connections (see **fig. 7**).

Let us now see how to protect persons in each case.

Additional letter	Earthing of the MV/LV substation	Earthing of the LV neutral	Earthing of the LV application
R (connected)	■	■	■
N (of neutral)	■	■	□
S (separated)	□	□	□

(■ = interconnected, □ = separate)

Fig. 7 : linking of LV earth connections with that of the MV/LV substation.

2.1 TN system

When an insulating fault is present, the fault current I_d is only limited by the impedance of the fault loop cables (see **fig. 8**):

$$I_d = \frac{U_0}{R_{ph_1} + R_d + R_{PE}}$$

For a feeder and as soon as $R_d \approx 0$:

$$I_d = \frac{0.8 U_0}{R_{ph_1} + R_{PE}}$$

In point of fact, when a short-circuit occurs, it is accepted that the impedances upstream from the relevant feeder cause a voltage drop of around

20 % on phase-to-neutral voltage U_0 , which is the nominal voltage between phase and earth.

I_d thus induces a fault voltage with respect to earth:

$$U_d = R_{PE} I_d$$

i.e.:

$$U_d = 0.8 U_0 \frac{R_{PE}}{R_{ph_1} + R_{PE}}$$

For 230/400 V networks, this voltage of around $U_0/2$ (if $R_{PE} = R_{ph}$) is dangerous since it exceeds the limit safety voltage, even in dry

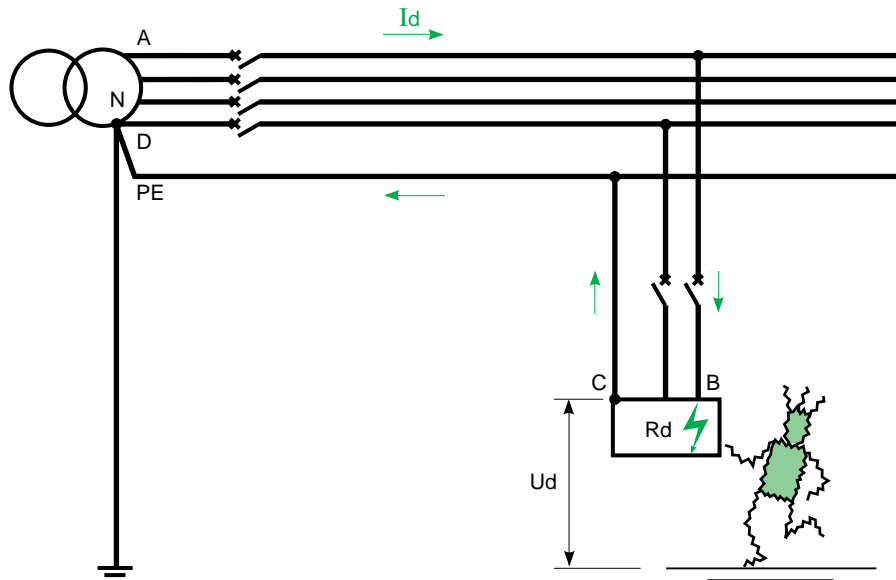

$$U_d \approx \frac{0.8 U_0}{2} \text{ if } R_{PE} = R_{ph} \text{ and } R_d = 0$$

$$I_d = \frac{U_0}{R_{AB} + R_d + R_{CD}} \Rightarrow \frac{0.8 U_0}{R_{ph} + R_{PE}}$$

Fig. 8 : fault current and voltage in TN system.

atmospheres ($U_L = 50$ V). The installation or part of the installation must then be automatically and promptly de-energised (see **fig. 9**).

As the insulation fault resembles a phase-neutral short-circuit, breaking is achieved by the Short-Circuit Protection Device (SCPD) with a maximum specified breaking time depending on U_L .

Implementation

To be sure that the protection device really is activated, the current I_d must be greater than the operating threshold of the protection device I_a ($I_d > I_a$) irrespective of where the fault occurs. This condition must be verified at the installation design stage by calculating the fault currents for all the distribution circuits.

If the same path is taken by the protective conductor - PE- and the live conductors, this will simplify the calculation. Certain country standards recommend this.

To guarantee this condition, another approach consists in imposing a maximum impedance value on the fault loops according to the type and rating of the SCPDs chosen (see British standard BS 7671). This approach may result in increasing the cross-section of the live and/or protective conductors.

Another means of checking that the device will ensure protection of persons is to calculate the maximum length not to be exceeded by each feeder for a given protection threshold I_a .

To calculate I_d and L_{max} , three simple methods can be used (see "Cahier Technique" n° 158):

- the impedance method;
- the composition method;
- the conventional method.

The latter gives the following equation:

$$I_d = \frac{0.8 U_o}{Z} = \frac{0.8 U_o}{R_{ph} + R_{PE}} = \frac{0.8 U_o S_{ph}}{\rho (1+m) L}$$

For the protection device to perform its function properly, I_a must be less than I_d , hence the expression of L_{max} , the maximum length authorised by the protection device with a threshold I_a :

$$L_{max} = \frac{0.8 U_o S_{ph}}{\rho (1+m) I_a}$$

- L_{max} : maximum length in m;
- U_o : phase-to-neutral voltage 230 V for a three-phase 400 V network;
- ρ : resistivity to normal operating temperature;
- I_a : automatic breaking current:
 - for a circuit-breaker $I_a = I_m$ (I_m operating current of the magnetic or short time delay trip release),
 - for a fuse, current such that total breaking time of the fuse (prearcing time + arcing time) complies with the standard (see **fig. 9**),

$$m = \frac{S_{ph}}{S_{PE}}$$

If the line is longer than L_{max} , either conductor cross-section must be increased or it must be protected using a Residual Current Device (RCD).

U _o (volts) phase/neutral voltage	Breaking time (seconds) U _L = 50 V	Breaking time (seconds) U _L = 25 V
127	0.8	0.35
230	0.4	0.2
400	0.2	0.05
> 400	0.1	0.02

Fig. 9 : breaking time in TN system (taken from IEC 60364 tables 41 and 48A).

2.2 TT system

When an insulation fault occurs, the fault current I_d (see **fig. 10**) is mainly limited by the earth resistances (if the earth connection of the frames and the earth connection of the neutral are not associated).

Still assuming that $R_d = 0$, the fault current is:

$$I_d \approx \frac{U_o}{R_a + R_b}$$

This fault current induces a fault voltage in the earth resistance of the applications:

$$U_d = R_a I_d, \text{ or } U_d = \frac{U_o R_a}{R_a + R_b}$$

As earth resistances are normally low and of the same magnitude ($\approx 10 \Omega$), this voltage of the order of $U_o/2$ is dangerous. The part of the

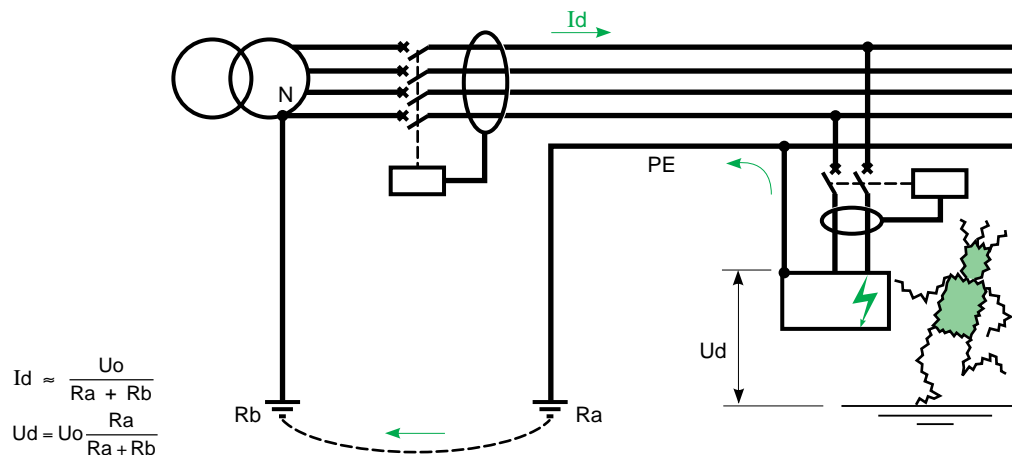

Fig. 10 : fault current and voltage in TT system.

installation affected by the fault must therefore be automatically disconnected (see fig. 11).

Implementation

As the fault current beyond which a risk is

present ($I_{d0} = \frac{U_L}{R_a}$) is far lower than the settings

of the overcurrent protection devices, at least one RCD must be fitted at the supply end of the installation. In order to increase availability of electrical power, use of several RCDs ensures time and current discrimination on tripping. All these RCDs will have a nominal current threshold $I_{\Delta n}$ less than I_{d0} .

The standard stipulates that de-energising by the RCDs must occur in less than 1 s.

Note that protection by RCD:

- does not depend on cable length;
- authorises several separate R_a earth connections (an unsuitable measure since the

PE is no longer a unique potential reference for the entire installation).

"Cahier Technique" no. 114 gives a detailed description of RCD technology and use.

$I_{\Delta n} \leq \frac{U_L}{R_a}$	Maximum resistance of earth connection	
	U_L	
	50 V	25 V
3 A	16 Ω	8 Ω
1 A	50 Ω	25 Ω
500 mA	100 Ω	50 Ω
300 mA	166 Ω	83 Ω
30 mA	1,660 Ω	833 Ω

Fig. 11 : upper limit of the resistance of the frame earth connection not to be exceeded according to RCD sensitivity and limit voltage U_L [$I_{\Delta n} = F(R_a)$].

2. 3 IT system

The neutral is unearthed, i.e. not connected to the earth. The earth connections of the frames are normally interconnected (just like the TN and TT earthing systems).

■ In normal operation (without insulation fault), the network is earthed by the network leakage impedance.

We remind you that natural earth leakage impedance of a three-phase 1 km long cable is characterised by the standard values:

- $C = 1 \mu\text{F} / \text{km}$,
 - $R = 1 \text{M}\Omega / \text{km}$,
- which give (in 50 Hz):
- $Z_{cf} = 1 / j C \omega = 3,200 \Omega$,

□ $Z_{rf} = R_f = 1 \text{M}\Omega$,
therefore $Z_f \approx Z_{cf} = 3,200 \Omega$.

In order to properly set the potential of a network in IT with respect to the earth, we advise that you place an impedance ($Z_n \approx 1,500 \Omega$) between transformer neutral and the earth.... this is the IT impedance-earthed system.

■ Behaviour on the first fault

□ Unearthed neutral:

The fault current is formed as follows (maximum value in the case of a full fault and neutral not distributed).

If $I = I_{c1} + I_{c2}$, where:

$$I_{c1} = j C_f \omega V_{13},$$

$$I_{C2} = j C_f \omega V_{23}$$

$$I_d = U_{o3} C_f \omega.$$

For 1 km of 230/400V network, the fault voltage will be equal to:
 $U_c = R_b I_d$, i.e. 0.7 V if $R_b = 10 \Omega$.

This voltage is not dangerous and the installation can thus be kept in operation.

If the neutral is distributed, the shift of neutral potential with respect to the earth adds a current $I_{cN} = U_o C_f \omega$ and $I_d = U_o 4 C_f \omega$ (see **fig. 12**).

□ impedance-earthed neutral:
 First fault current:

$$I_d = \frac{U}{Z_{eq}} \text{ where}$$

$$\frac{1}{Z_{eq}} = \frac{1}{Z_n} + 3j C_f \omega$$

The corresponding fault voltage is still low and not dangerous; the installation can be kept in operation.

Although risk-free continuity of service is a great advantage, it is necessary:
 - to know that there is a fault,
 - to track it and eliminate it promptly,
 before a second fault occurs.

To meet this need:

- the fault information is provided by an Insulation Monitoring Device (IMD) monitoring all live conductors, including the neutral,
- locating is performed by means of fault trackers.

■ behaviour on the second fault

When a second fault occurs and the first fault has not yet been eliminated, there are three possibilities:

- the fault concerns the same live conductor: nothing happens and operation can continue,
- the fault concerns two different live conductors: if all the frames are inter-connected, the double fault is a short-circuit (via the PE). The Electric Shock hazard is similar to that encountered with the TN system. The most unfavourable conditions for the SCPDs (smallest I_d) are obtained when both faults occur on feeders with the same characteristics (cross-sections and lengths) (see **fig. 13**).

The SCPDs have to comply with the following relationships:

- if the neutral is distributed and
- one of the two faulty conductors is the neutral:

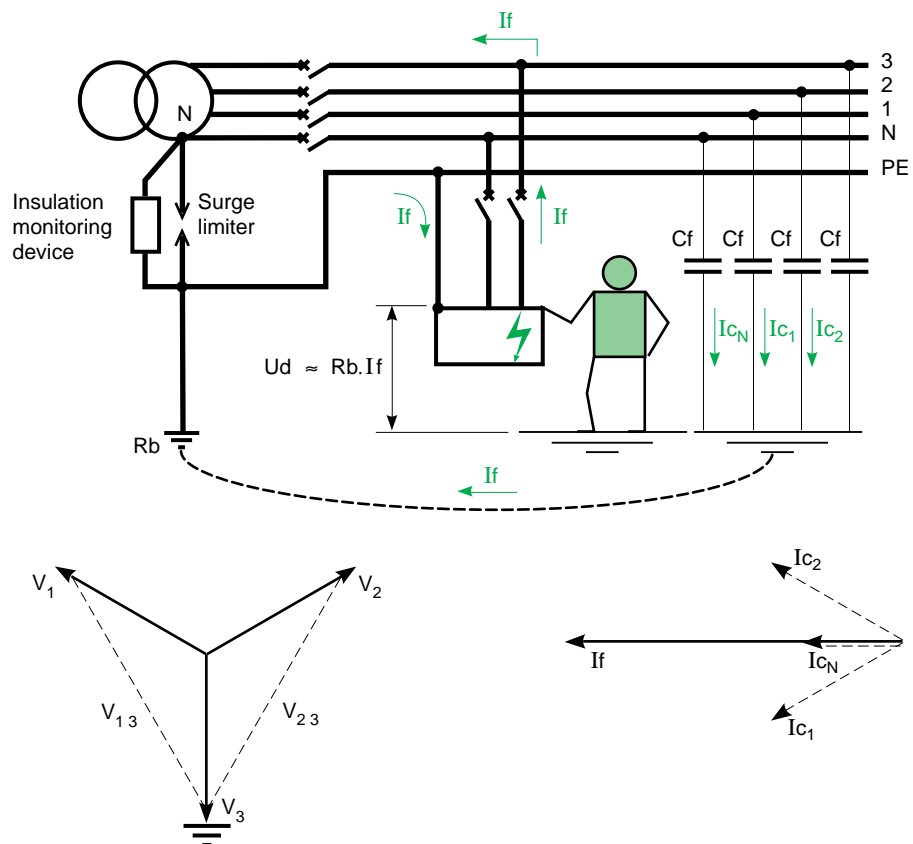

Fig. 12 : first insulation fault current in IT system.

$$I_a \leq \frac{0.8 U_o}{2 Z}$$

- or if the neutral is not distributed:

$$I_a \leq \frac{0.8 U_o \sqrt{3}}{2 Z}$$

Note that if one of the two faults is on the neutral, the fault current and fault voltage are twice as low as in the TN system. This has resulted in standard makers authorising longer SCPD operating times (see **fig. 14**).

Just as in the TN earthing system, protection by SCPD only applies to maximum cable lengths:

- distributed neutral:

$$L_{max} = \frac{1}{2} \frac{0.8 U_o S_{ph}}{\rho (1+m) I_a}$$

- non-distributed neutral:

$$L_{max} = \frac{\sqrt{3}}{2} \frac{0.8 U_o S_{ph}}{\rho (1+m) I_a}$$

This is provided that the neutral is protected and its cross-section equal to phase cross-section... This is the main reason why certain country standards advise against distributing the neutral.

□ case where all frames are not interconnected. For frames earthed individually or in groups, each circuit or group of circuits must be protected by a RCD.

In point of fact, should an insulation fault occur in groups connected to two different earth connections, the earthing system's reaction to the insulation fault (I_d , U_d) is similar to that of a TT system (the fault current flows through the earth).

Protection of persons against indirect contacts is thus ensured in the same manner

$$I \Delta n \leq \frac{U_L}{R_a} \quad (\text{see table in figure 11}).$$

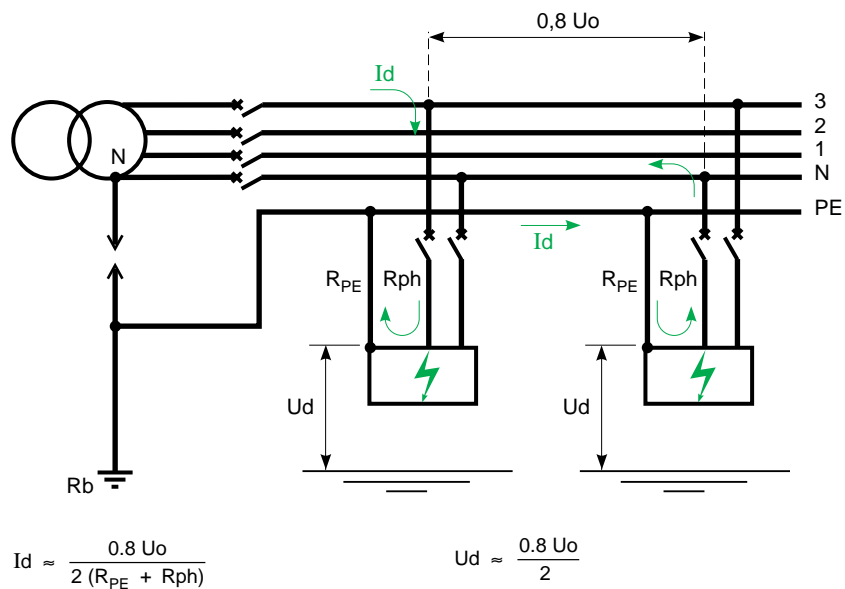

Fig. 13 : 2nd insulation fault current in IT system (distributed neutral) and relevant feeders with the same cross-section and length.

Uo/U (volts) Uo: phase/neutral voltage U: phase to phase voltage	UL = 50 V breaking time (seconds)		UL = 25 V breaking time (seconds)	
	Neutral not distributed	Neutral distributed	Neutral not distributed	Neutral distributed
127/220	0.8	5	0.4	1.00
230/400	0.4	0.8	0.2	0.5
400/690	0.2	0.4	0.06	0.2
580/1 000	0.1	0.2	0.02	0.08

Fig. 14 : maximum breaking times specified in IT system (as in IEC 60364 tables 41B and 48A).

Note that in view of the times specified by the standard, horizontal time discrimination can be achieved to give priority to continuity of service on certain feeders.

Note: in order to protect LV unearthed networks (IT) against voltage rises (arcing in the MV/LV transformer, accidental contact with a network of higher voltage, lightning on the MV network), French standard NF C 15-100 stipulates that a surge limiter must be installed between the

neutral point of the MV/LV transformer and the earth (R_b).

Readers wishing to study the IT earthing systems in greater detail should read "Cahier Technique" no. 178.

So as to obtain a concise overview of the quantities characterising the various earthing systems, as regards protection of persons, the main formulas are listed in the table in **figure 15**.

		Id	Ud	Lmax	Continuity of service
TN		$\frac{0.8 U_0 S_{ph}}{\rho (1+m) L}$	$\frac{0.8 U_0}{1+m}$	$\frac{0.8 U_0 S_{ph}}{\rho (1+m) I_a}$	Vertical discrimination
TT		$\frac{U_0}{R_a + R_b}$	$\frac{U_0 R_a}{R_a + R_b}$	No constraint	Vertical discrimination
IT	1st fault	$< 1 \text{ A}$	$\ll U_L$		No tripping
	Double fault with distributed neutral	$\leq \frac{1}{2} \frac{0.8 U_0 S_{ph}}{\rho (1+m) L}$	$\leq \frac{m}{2} \frac{0.8 U_0}{1+m}$	$\frac{1}{2} \frac{0.8 U_0 S_{ph}}{\rho (1+m) I_a}$	Vertical discrimination and possibility of horizontal discrimination to the advantage of high current feeders
	Double fault with non distributed neutral	$\leq \frac{\sqrt{3}}{2} \frac{0.8 U_0 S_{ph}}{\rho (1+m) L}$	$\leq \frac{m \sqrt{3}}{2} \frac{0.8 U_0}{1+m}$	$\frac{\sqrt{3}}{2} \frac{0.8 U_0 S_{ph}}{\rho (1+m) I_a}$	

Remember that:

■ $\rho = 22 \cdot 10^{-3} \Omega \cdot \text{mm}^2/\text{m}$ for Cu (36 for Al) at 75°C;

■ $m = \frac{S_{ph}}{S_{PE}}$;

■ PE cross-section, normally equal to phase cross-section, can be equal to half of phase cross-section when the latter exceeds 35 mm².... thus increasing Ud in TN and IT.

Fig. 15 : characteristic quantities of earthing systems.

3 Earthing systems confronted with fire and electrical power unavailability hazards

3.1 Fire

It has been proved, then accepted by standard makers, that contact between a conductor and a metal part can cause fire to break out, in particularly vulnerable premises, when the fault current exceeds 500 mA.

To give an example:

- premises particularly at risk: petrochemical factories, farms;
- premises averagely at risks, but where consequences may be very serious: very high buildings receiving the general public...

In the unearthed neutral system, the risk of "fire":

- is very small on the first fault;
- is as important as in TN on the second fault.

For the TT and TN earthing systems, the fault current is dangerous given the power developed ($P = R_d I^2$):

- in TT = $5A < I_d < 50 A$;
- in TN = $1 kA < I_d < 100 kA$.

The power present where the fault has occurred is considerable, particularly in the TN system, and prompt action is vital as from the lowest current levels in order to limit the dissipated energy ($\int R_d i^2 dt$).

This protection, specified by the IEC and a requirement of French standards (NF C 15-100, paragraph 482-2-10) is provided by an instantaneous RCD with threshold ≤ 500 mA, regardless of the earthing system.

When risk of fire is especially high (manufacture/storage of inflammable materials....) it is necessary and indeed compulsory to use an earthing system with earthed frames which naturally minimises this hazard (TT or IT).

Note that the TN-C is banned in certain countries when a risk of fire and/or explosion is present: as the PE and neutral conductors are one and the same, RCDs cannot be used.

3.2 Electrical power unavailability

This hazard is a major one for operators, since it results in non-production and repair costs which can be high.

It varies according to the earthing system chosen.

We remind you that availability (D) is a statistical quantity (see **fig. 16**) equal to the ratio between two periods of time:

- time during which the mains is present;
- reference time equal to the time "mains present + mains absent".

Mean Down Time (MDT) also depends on the fault current and in particular on its strength which, according to its value, may cause:

- damage of varying degrees to loads, cables...;
- fires;

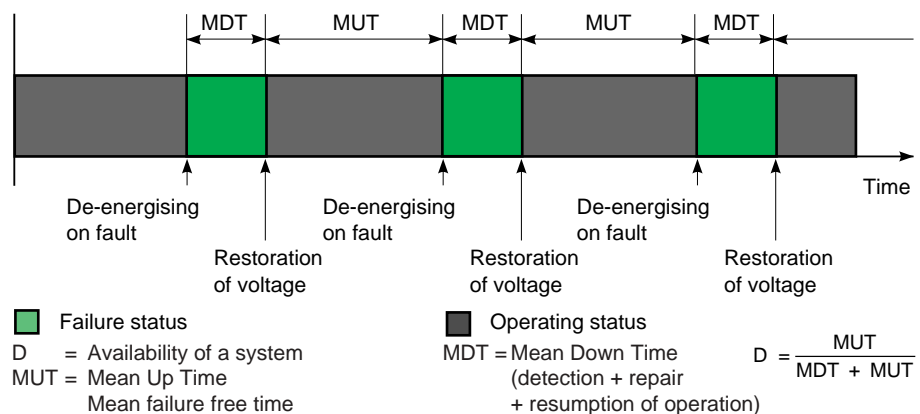

Fig. 16 : availability of electrical power.

- malfunctionings on the low current control and monitoring equipment.

Each earthing system must therefore be examined as regards availability of electrical power, with special emphasis on the IT earthing system since it is the only one that authorises non-tripping in the presence of a fault.

- The IT earthing system

In order to retain the advantage of this system, i.e. not interrupting electrical distribution on the first fault, the second fault must be prevented, since this then presents the same high risks as the TN system. The first fault must therefore be eliminated before a second fault occurs. The use of efficient detection and locating methods and the presence of a reactive maintenance team considerably reduces the likelihood of the "double fault".

Moreover, monitoring devices are currently available which monitor in time the evolution in insulation of the various feeders, perform fault prediction and thus anticipate maintenance of the first fault.

This ensures maximum availability with the IT earthing system.

- The TN and TT earthing systems

These systems use discrimination on tripping. In TN, this is acquired with short-circuit protection devices if the installation protection plan has been properly designed (discrimination by current and duration selectivity). In TT, it is easy to implement thanks to the RCDs which ensure current and time discrimination.

Remember that, in TN system, repair time according to $\int i^2 dt$, may be longer than in TT system, which also affects availability.

- For all the earthing systems

It is always useful to anticipate insulation faults and in particular those of certain motors before startup.

Bear in mind that 20 % of motor failures are due to an insulation fault which occurs on energising. In point of fact, an insulation loss, even small, on a hot motor cooling down in a damp atmosphere (condensation) degenerates into a full fault on restarting, causing both considerable damage to windings and production loss and even major risks if the motor has a safety function (drainage, fire, fan pump motor, etc.).

This type of incident can be prevented, whatever the earthing system, by an Insulation Monitoring Device monitoring the load with power off. If a fault occurs, startup is then prevented. To round off this section on "the hazard presented by electrical power unavailability" it is clear that, regarding proper electrical power availability, the earthing systems can be listed in the following order of preference: IT, TT, TN.

Note:

If, to ensure continuity of service, the installation is fitted with a generator set or a UPS (Uninterruptible Power Supply) in "off line", there is a risk of failure to operate or of delayed operation of the SCPDs (the short-circuit current is lower) on changeover to the replacement source (lowest I_{sc} - see [fig. 17](#)).

In TN and IT, for safety of persons and property, it is thus vital to check that the protection conditions are always met (operating time and threshold), especially for very long feeders. If this is not so, then RCDs must be used.

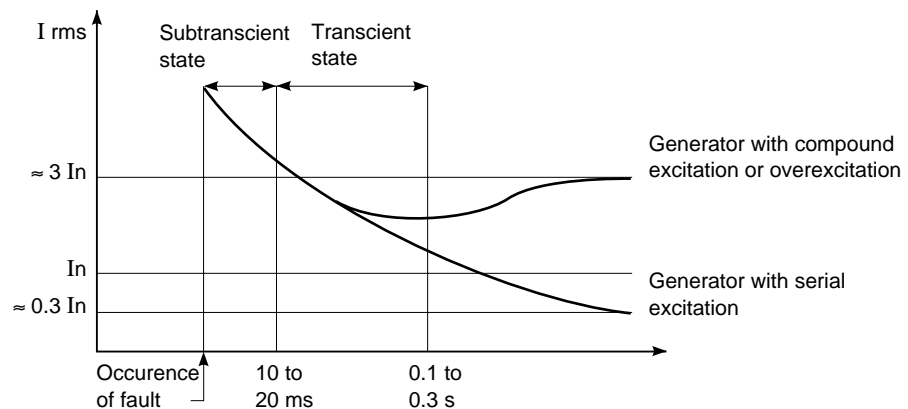

Fig. 17 : making a short-circuit in a network supplied by a diesel standby generator.

4 Influences of MV on LV, according to the earthing systems

LV networks, unless a replacement uninterruptible power supply (with galvanic insulation) or a LV/LV transformer is used, are influenced by MV.

This influence takes the form of:

- capacitive coupling: transmission of overvoltage from MV windings to LV windings;
- galvanic coupling, should disruptive breakdown occur between the MV and LV windings;
- common impedance, if the various earth connections are connected and a MV current flows off to earth.

This results in LV disturbances, often overvoltages, whose generating phenomena are MV incidents:

- lightning;
- operating overvoltages;
- MV-frame disruptive breakdown inside the transformer;
- MV-LV disruptive breakdown inside the transformer.

Their most common consequence is destruction of LV insulators with the resulting risks of Electric Shock of persons and destruction of equipment.

4.1 Lightning

If the MV network is an overhead one, the distributor installs ZnO lightning arresters to limit the effects of a direct or an indirect lightning stroke.

Placed on the last pylon before the MV/LV substation, these lightning arresters limit overvoltage and cause lightning current to flow off to earth (see "Cahiers Techniques" no. 151 and 168).

A lightning wave, however, is transmitted by capacitive effect between the transformer windings, to the LV live conductors and can reach 10 kV peak. Although it is progressively weakened by the stray capacities of the network

with respect to earth, it is advisable to install surge limiters (lightning arresters) at the origin of the LV network, whatever earthing system is used (see [fig. 18](#)).

Likewise, to prevent coupling by common impedance, it is wise never to connect the following to the earth connection of the LV neutral:

- MV lightning arresters;
 - lightning rods placed on the roof of buildings.
- In point of fact, the lightning current would cause a rise in potential of the PE and/or the LV neutral (risk of disruptive breakdown by return) and loss of earth connection effectiveness by vitrification.

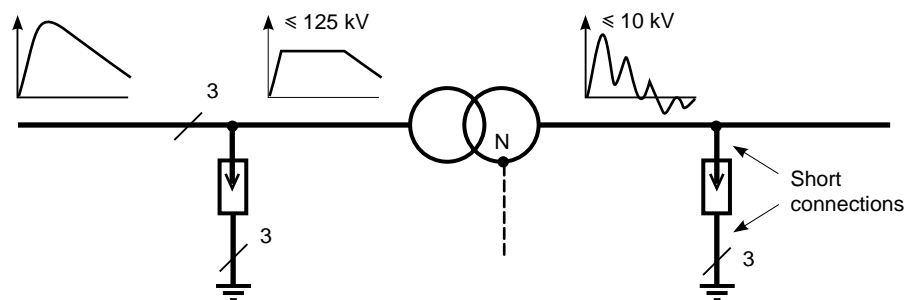

Fig. 18 : limitation and transmission of lightning overvoltages (whether or not the neutral is earthed, there are common mode overvoltages on phases).

4.2 Operating overvoltages

Some MV switchgear (e.g. vacuum circuit-breakers) cause considerable overvoltages when operated (see "Cahier Technique" no. 143).

Unlike lightning which is a common mode disturbance (between network and earth), these overvoltages are, in LV, differential mode

disturbances (between live conductors) and are transmitted to the LV network by capacitive and magnetic coupling.

Just like all differential mode phenomena, operating overvoltages do not interfere, or only very slightly, with any of the earthing systems.

4.3 MV-frame disruptive breakdown of the transformer

On MV-frame disruptive breakdown inside the transformer and when the transformer frame and LV installation neutral are connected to the same earth connection, a MV "zero sequence" current (whose strength depends on the MV earthing system) can raise the frame of the transformer and neutral of the LV installation to a dangerous potential.

In point of fact, the value of the transformer earth connection directly conditions the contact voltage

in the substation $U_t \leq R_p I_{h_{MV}}$ and the dielectric withstand voltage of the LV equipment in the substation $U_{tp} = R_p I_{h_{MV}}$ (if the LV neutral earth is separate from the substation one). The earth connections of the substation and of the LV neutral are not generally connected. If however they are, a limit is given to the common earth connection value to prevent a rise in potential of the LV network compared with the deep earth. **Figure 19** gives the common earth

Diagrams (1)

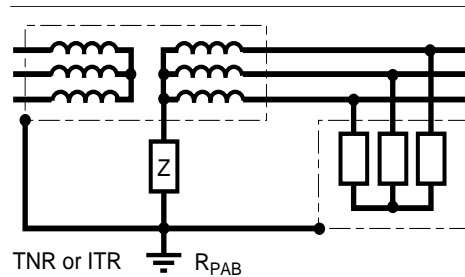

TNR or ITR R_{PAB}

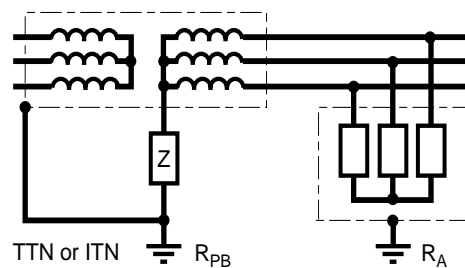

TTN or ITN R_{PB} R_A

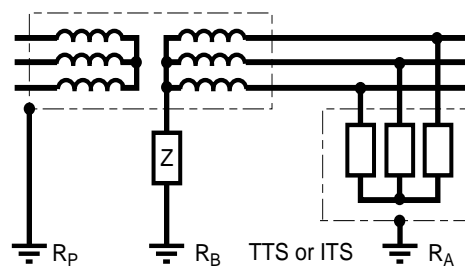

R_P R_B TTS or ITS R_A

Maximum resistance of the earth connection of substation frames R_p (Ω)

No value stipulated but the following values prevent excessive potential rise of the assembly

$I_{h_{MV}}$ (A)	R_{PAB} (Ω)
300	3 to 20
1,000	1 to 10

$I_{h_{MV}}$ (A)	R_{PB} (Ω)
300	3
1,000	1

U_{tp} (kV)	2	4	10
$I_{h_{MV}}$ (A)	R_p (Ω)		
300	4	8	20
1,000	1	3	10

Z: direct earthing in TN and TT impedance-earthed or unearthed in IT with presence of a discharger.

$I_{h_{MV}}$: maximum strength of the first earth single-phase fault current of the high voltage network supplying the substation.

U_{tp} : power frequency withstand voltage of the low voltage equipment of the substation.

(1) the third letter of the earthing systems means:

- all the frames are linked R;
- the substation frame is connected to the Neutral frame: N;
- the earth connections are Separated S.

Fig. 19 : maximum resistance of the earth connection of the substation frames according to network earthing system.

connection values for the $I_{h_{MV}}$ values of French public networks. Readers interested in this can consult standard IEC 364-4-442 which explains the risks according to LV earthing systems.

Still for public networks (except for Australia and the USA where the fault current can be very high), values encountered range from 10 A in Ireland (an impedance compensates the capacitive current) to 1,000 A in France (underground networks) and in Great Britain.

MV industrial networks are normally run in impedance-earthed IT and have a zero sequence current $I_{h_{MV}}$ of a few dozens of amps (see "Cahier Technique" no. 62).

The maximum value authorised for the earth connection depends on the equipotentiality conditions of the frames of the LV network, i.e. on its earthing system.

4.4 MV-LV disruptive breakdown inside the transformer

To prevent potential with respect to the earth of the LV network from rising to the phase-to-neutral voltage of the MV network on MV-LV disruptive breakdown inside the transformer, the LV network must be earthed.

The consequences of this fault are:

■ in TN

The entire LV network, including the PE, is subjected to voltage $I_{h_{MV}} R_{PAB}$ or R_{AB} . If this overvoltage exceeds the dielectric withstand of the LV network (in practice of the order of 1,500 V), LV disruptive breakdowns are possible if the equipotentiality of all the frames, electrical or not, of the building is not complete;

■ in TT

Whereas the load frames are at the potential of the deep earth, the entire LV network is subjected to $I_{h_{MV}} R_{PB}$ or R_B : there is a risk of disruptive breakdown "by return" of loads if the voltage developed in RPB or RB exceeds their dielectric withstand;

■ in IT

Operation of a discharger/short-circuiter (known as a surge limiter in France), which short-circuits itself as soon as its arcing voltage is reached, then brings the problem to the level of the

TN network one (or TT if there are several application earth connections).

In all cases, MV/LV disruptive breakdowns give rise to constraints which can be severe, both for the LV installation and loads, if the value of the LV neutral earth connection is not controlled. Interested readers can consult IEC 364 which explains risks according to the earthing systems.

The example of overhead public distribution in France provides a solution to a situation where risks of lightning, operating overvoltage and transformer frame-MV and MV-LV disruptive breakdown are present (see fig. 20). It shows that equipotentiality of the entire distribution (all MV frames, neutrals and application frames connected) is not vital: each risk is dealt with separately.

This section has described the influence of the MV network. Its conclusions are:

■ the value of using lightning arresters at the origin of the LV installation, whatever the earthing system type, if the MV and particularly the LV supply is overhead;

■ connection of the earth connection of the substation with the earth connection of the LV neutral or with those of the application frames, imposes variable constraints on the LV network according to the MV earthing system (value of I_h).

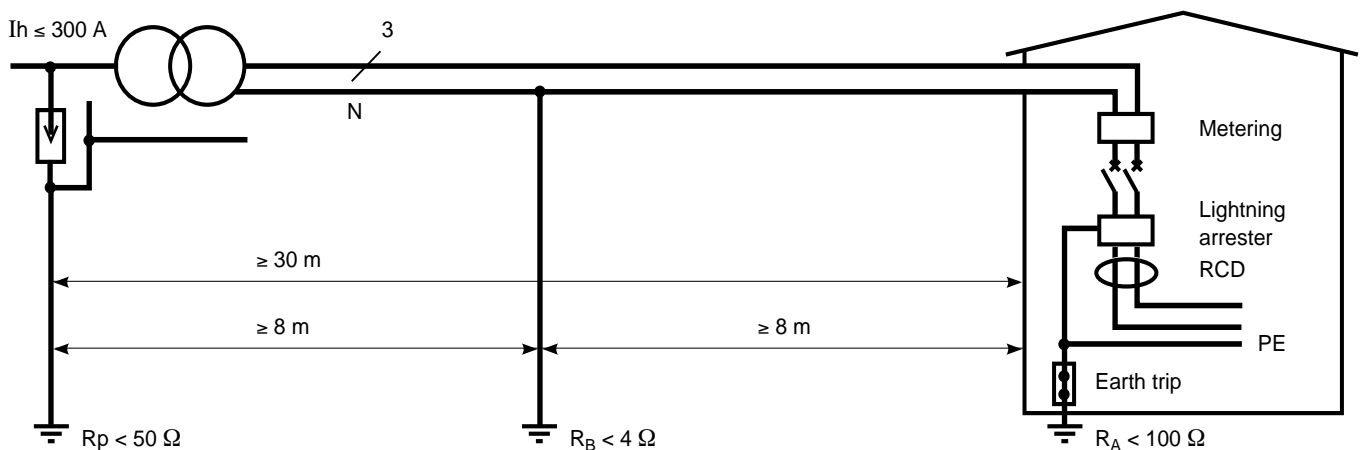

Fig. 20 : rural overhead public distribution in France.

5 Switchgear linked to the choice of earthing system

Choice of earthing system affects not only **dependability** (in the largest sense) but also installation, in particular with respect to the switchgear to be implemented.

5.1 TN system

In this system the SCPDs (circuit-breaker or fuses) generally provide protection against insulation faults, with automatic tripping according to a specified maximum breaking time (depending on phase-to-neutral voltage U_0 : see fig. 9).

■ with circuit-breaker

Circuit-breaker tripping occurs at a level determined by the type of the tripping release (see fig. 21). As soon as the fault current exceeds the threshold of the short-circuit protection trip release (generally "instantaneous"), opening occurs in a time far shorter than specified maximum breaking time, for example 5 s for distribution circuits and 0.4 s for terminal circuits.

When impedance of the source and cables is high, either low threshold trip releases must be used or RCDs associated with the SCPDs. These RCDs may be separate residual current devices or be combined with circuit-breakers (residual current circuit-breakers) of low sensitivity. Their threshold must be:

$$I\Delta n < \frac{0.8 U_0}{R_{ph} + R_{PE}}$$

Use of a RCD has the advantage of making loop impedance checking unnecessary, a fact which is of particular value when the installation is modified or extended.

This solution is clearly not applicable with a TN-C type earthing system (the protective conductor being the same as the neutral one).

■ with fuses

The fuses used for short-circuit protection are of the gG type and their time/current characteristics (see fig. 22) are defined by standards (household fuses: IEC 60241, industrial fuses: IEC 60269). Checking suitability with the maximum specified breaking time therefore calls for individual validation of the ratings provided for each protection device. If they are not suitable, either fault loop impedance must be reduced (increased cross-sections) or the fuse must be replaced by a low threshold or a residual current circuit-breaker.

	Trip release type	Operating threshold
Household (EN 60898)	B	$3 I_n \leq I_a \leq 5 I_n$
	C	$5 I_n \leq I_a \leq 10 I_n$
	D	$10 I_n \leq I_a \leq 20 I_n$
Industrial (IEC 60947-2)	G (low threshold)	$2 I_n \leq I_a \leq 5 I_n$
	D	$5 I_n \leq I_a \leq 10 I_n$
	MA (for motor starter)	$6.3 I_n \leq I_a \leq 12.5 I_n$

Fig. 21 : tripping current (magnetic or short time delay) of LV circuit-breakers.

I_n gG (A)	$I_{min. 10 s}$	$I_{max. 5 s}$	$I_{min. 0.1 s}$	$I_{max. 0.1 s}$
63	160	320	450	820
80	215	425	610	110
100	290	580	820	1,450

Fig. 22 : example of fuse operating threshold limits (as in IEC 60269 paragraph 5-6-3).

5.2 TT system

With this system, the small value of the fault currents (see previous section) does not allow the SCPDs to protect persons against indirect contacts. RCDs (see **fig. 23 & 24**) need to be used, associated with circuit-breakers or switches (see IEC 60364 - paragraph 413.1.4.2).

These devices must meet the following standards in particular:

- IEC 60755: general rules;
- IEC 61008: "household" residual current switches;

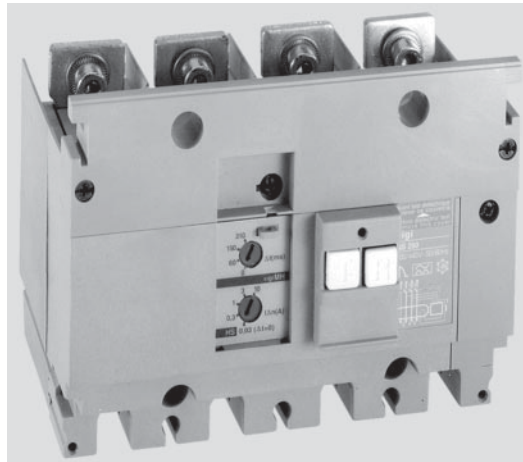

Fig. 23 : Vigi module of a Compact NS.

- IEC 61009: «household» residual current SCPDs;

- IEC 60947-2: «industrial» residual current circuit-breakers.

Their implementation must meet the objectives for:

- protection of persons, i.e.:
 - threshold $I_{\Delta n} \leq U_L/R_A$,
 - breaking time ≤ 1 s;
- continuity of service with thresholds and time delays enabling current and time discrimination;
- fire protection with $I_{\Delta n} \leq 500$ mA.

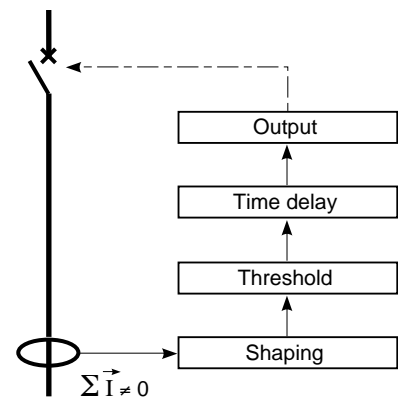

Fig. 24 : functional diagram of an RCD.

5.3 IT system

Remember that in the event of a double fault, safety of persons is provided by the SCPDs. When the first insulation fault occurs, the calculation proved there was no risk (contact voltage lower than limit safety voltage). Automatic de-energising is therefore not compulsory: this is the main advantage of this system.

To retain this advantage, standards recommend (IEC 60364 - paragraph 413.1.5.4) or stipulate (NF C 15-100) the use of an Insulation Monitoring Device (IMD) and locating of the first fault. In point of fact, if a second fault occurs, automatic breaking is vital due to the Electric Shock risk: this is then the role of the SCPDs backed up by the RCDs if required.

Locating the first fault for repairs (curative maintenance) is considerably simplified by the use of a Ground Fault Location Device (GFLD).

Predictive maintenance, based on the monitoring (recording) of variations in insulation impedance of each circuit, is also possible.

LV networks, using the IT system, which take their origin at a MV/LV transformer, must be protected against risks of insulation faults between MV and LV by a «surge limiter». Finally, to fix the potential of the LV network with respect to the earth (short network supplied by a MV/LV transformer), an impedance can be installed between the transformer neutral and the earth. Its value in 50 Hz, of the order of 1,500 W, is very high in DC and in very low frequency so as not to obstruct insulation measurement and fault locating.

- Operating principle of the IMDs

A fault on a circuit results in a drop in insulation, or more precisely in resistance of the network compared with earth.

In France, the IMDs and GFLDs have to comply with manufacturing standard UTE 63080.

The purpose of the IMDs is thus to monitor the value of this resistance. They normally work by injecting an AC or DC current between the

network and the earth and by measuring the value of this current (see **fig. 25**).

Injection of a DC current ensures continuous knowledge of network insulation resistance. If this resistance drops below a pre-set threshold, then the IMD reports the fault.

Injection of low frequency AC current ($F \approx$ a few hertz) monitors fault resistance but with a distortion due to the presence of network leakage capacitites. This minor drawback compared with injection frequency, is made up for by an advantage in first fault locating (one single injection device).

LF current injection devices are now available which can separately give the network's insulation resistance and reactance. Moreover, they enable locating of the first fault without circuit opening and without the problems due to highly capacitive feeders.

■ Operating principle of the GFLDs

The most common solution is to inject an identifiable current (with a frequency other than network one). The generator can be the IMD. Then, by means of magnetic Current Sensors (toroid transformers and/or clamp-on probe) associated with an amplifier tuned to the injected current frequency, to trace its path up to the fault (see **fig. 26**).

Finally, another solution is also used, which consists in comparing, constantly and for each

feeder, the value of its resistance with a pre-defined or programmable threshold value. This solution, computerised, enables the following actions, both locally and remotely:

- reporting of the first fault (IMD),

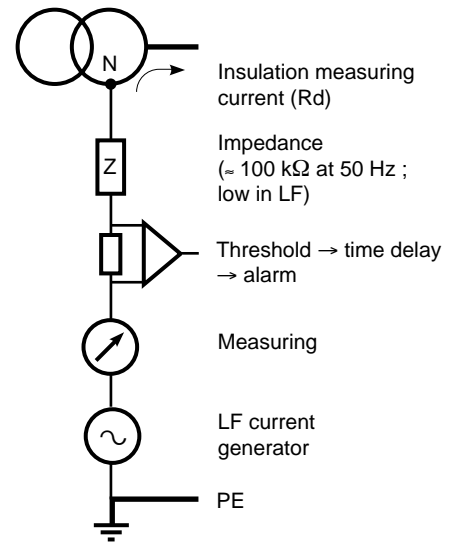

Fig. 25 : functional diagram of an Insulation Monitoring Device (IMD).

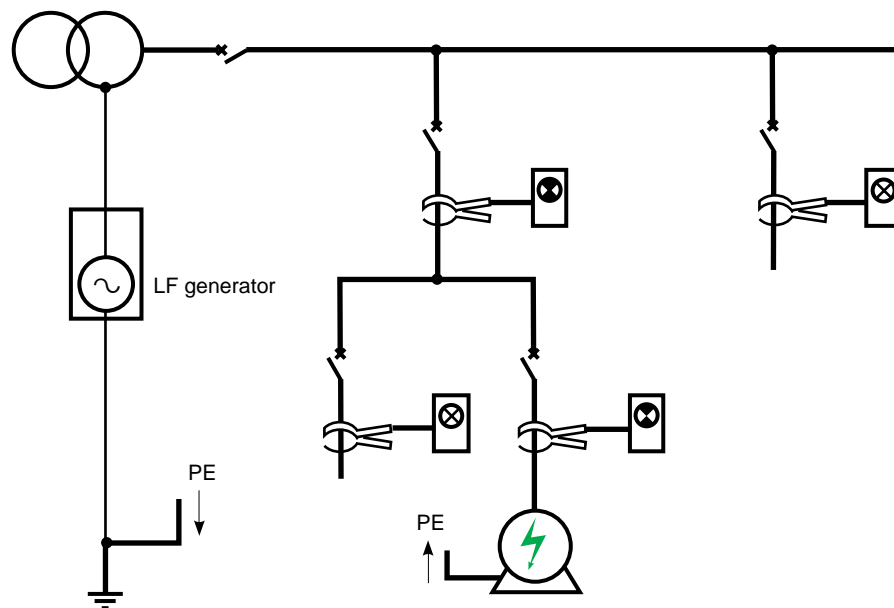

Fig. 26 : locating insulation faults by tracing the path of a low frequency current injected at the origin of the installation.

□ then locating of this fault (GFLD) to put it right (curative maintenance) (see **fig. 27**),

□ and knowledge of insulation evolution in time, feeder by feeder, to take action on feeders with abnormal insulation drops (predictive maintenance).

■ Surge limiters: these are connected between a live conductor (neutral or phase) of the installation and the earth. Their arcing voltage U_e must therefore be adapted to the assembly planned: thus there are two models for a 50 Hz 230/400 V network:

□ 250 V for connection to the neutral ($400 \text{ V} < U_e \leq 750 \text{ V}$),

□ 400 V, for connection to a phase ($700 \text{ V} < U_e \leq 1,100 \text{ V}$).

Their purpose is twofold:

□ limit voltage on the LV network on MV/LV disruptive breakdown in the distribution transformer. In this case, the limiter must flow off to earth the "residual" current of the MV network,

□ limit lightning overvoltages.

This accounts for their characteristics, for example for the 250 V model:

- rate voltage: 250 V,

- disruptive breakdown voltage at

50 Hz: min 400 V, max 750 V,

- disruptive breakdown voltage according to the 1.2/50 μ wave: $\hat{u} < 1,570 \text{ V}$,

- $\hat{i}_{\text{lightning}}$: 20 times 2,500 A (8/20 ms wave): without short-circuiting,

- $\hat{i}_{50 \text{ Hz}}$: 20,000 A / 0.2s,

5,000 A / 5 s,

1,200 A / 2 mn.

This $\hat{i}_{50 \text{ Hz}}$: peak current withstand is far greater than the value of the "residual" current of the MV network since a limiter which has been "arced" during a very high overvoltage may continue to be short-circuited and must therefore be still able to withstand a LV short-circuit current resulting from a first insulation fault in the protected LV network.

The limiters marketed under the Merlin Gerin brand can withstand 40 kA/0.2 s.

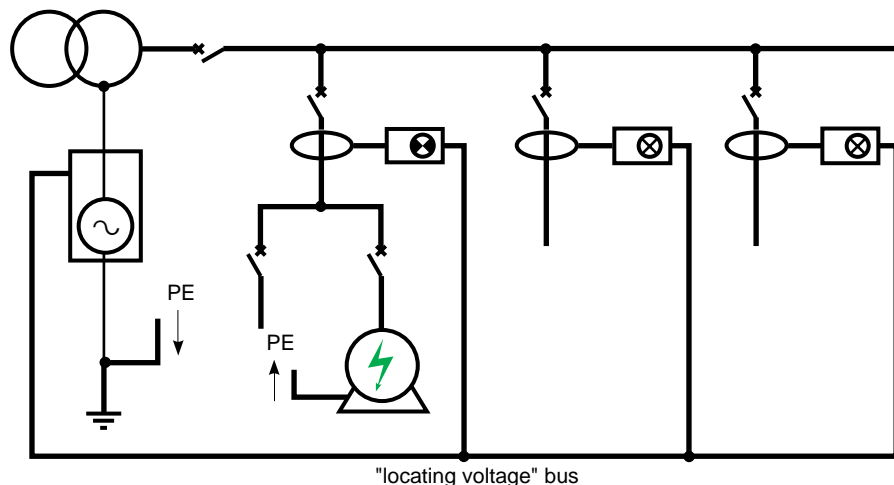

The locating current flowing in the conductors is detected by Current Sensors (CS). Each load comprising a discriminating amplifier (set to the frequency and phase of the locating current) calculates the resistance and capacity of the circuit (with the voltage and phase whose reference it obtains via a bus) and indicates the presence of the fault.

Fig. 27 : operating principle of an GFLD with LF impedance measurement.

5.4 Neutral protection according to the earthing system

The neutral must be broken by a multi-pole device:

■ in TT and TN, if neutral cross-section is less than phase cross-section;

■ in terminal distribution in view of the Neutral/Phase reversal risk.

The neutral must be protected and broken:

■ in IT for intervention of the protection device on the double fault, with one of the faults possibly on the neutral;

■ in TT and TN-S if neutral cross-section is less than phase cross-section;

■ for all earthing systems if the installation generates harmonic currents of rank 3 and multiples (especially if neutral cross-section is reduced).

In TN-C the neutral, which is also the PE, cannot be broken which is dangerous as a result of its potential variations, due to load currents and insulation fault currents.

To prevent risks, a local equipotentiality and an earth connection must be provided for each zone/consumer.

Figure 28 shows which types of circuit-breaker should be used for which earthing system. Note that TT and TN can use the same devices (with an additional residual current module in TT).

Circuits	Diagrams			
	TN-C	TN-S	TT	IT
Single phase circuits				
Single phase circuits with one protected pole  Two-pole circuit-breaker (1 protected pole, 2 de-energized poles)	no	yes	yes	no
Phase to neutral circuits with two protected poles  Two-pole circuit-breaker (with 2 protected poles)	no	yes	yes	yes
Three-phase circuits without neutral				
With three-pole protection  Three-pole circuit-breaker	yes	yes	yes	yes
Three-phase circuits with neutral				
Without overcurrent detection on neutral  Four-pole circuit-breaker with three protected poles	no	yes	yes	no
 Three-pole circuit-breaker	yes	yes	yes	no
With overcurrent detection on neutral  Four-pole circuit-breaker with four protected poles	no	yes	yes	yes

Fig. 28 : examples of circuit-breakers according to earthing systems.

6 Choice of earthing system and conclusion

The three earthing systems internationally used and standardised by IEC 60364 have as their common objective the quest for optimum **safety**.

As regards protection of persons, the 3 systems are equivalent if all installation and operating rules are complied with. In view of the characteristics specific to each system, no one system can be preferred over another.

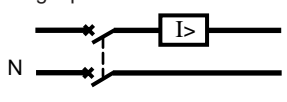
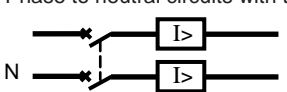
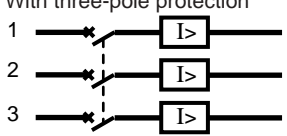
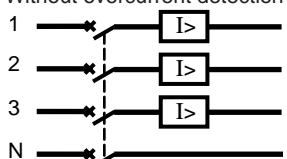
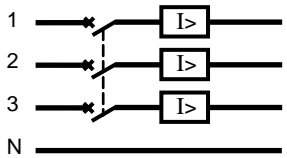
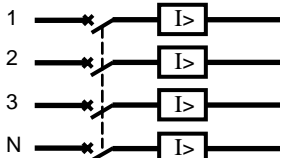
Rather, choice of earthing system must result from a concertation between the network user and designer (engineering firm, contractor, etc.) on:

- installation characteristics;
- operating conditions and requirements.

6.1 Methods for choosing the earthing system

■ Firstly **do not forget that the three earthing systems can all be included** in the same electrical installation: this guarantees the best possible answer to safety and availability needs;

■ Then **check that the choice is not specified or stipulated** by standards or legislation (decrees, ministerial decisions);

■ Then **dialogue with the user** to get to know his requirements and resources:

- need for continuity of service,
- whether or not there is a maintenance service,
- fire hazard.

Generally:

- continuity of service and maintenance service: the IT will be chosen,
- continuity of service and no maintenance service: no fully satisfactory solution: prefer the TT whose discrimination on tripping is easier to implement and which minimises damage with respect to the TN.

The installation of additional output is easily achieved without the necessity of further calculations.

□ continuity of service not essential and competent maintenance service: prefer the TN-S (rapid repairs and extensions performed according to rules),

□ continuity of service not essential and no maintenance service: prefer the TT,
□ fire hazard: IT if maintenance service and use of 0.5 A RCD or TT.

■ Allow for the special features of network and loads:

- very long network or, even more important, leakage current: prefer the TN-S,
- use of replacement or standby power supplies: prefer the TT,
- loads sensitive to high fault currents (motors): prefer the TT or IT,
- loads with low natural insulation (furnaces) or with large HF filter (large computers): prefer the TN-S,
- supply of control and monitoring systems: prefer the IT (continuity of service) or the TT (enhanced equipotentiality of communicating devices).

6.2 Conclusion

As there is no ideal choice with a single earthing system, it is thus advisable, **in many cases**, to implement several earthing systems in the same installation.

As a rule, a radial network installation, with a clear distinction between priority and non-priority circuits and using standby sources or uninterruptible power supplies, is preferable to an arborescent monolithic installation.

The purpose of this "Cahier Technique" was to perfect your knowledge of earthing systems; we hope it will enable you to optimise the **dependability** of your installations.

"Cahier Technique" no. 173 which provides an insight into use of earthing systems worldwide and their evolution will usefully complete this first document.

Bibliography

Standards

- IEC 60241: Fuses for domestic and similar purposes.
- IEC 60269: Low voltage fuses.
- IEC 60364: Electrical installation of buildings.
- IEC 60479: Effects of currents flowing through the human body.
- IEC 60755: General rules for residual current devices
- IEC 60947-2: Low voltage switchgear 2nd part: circuit-breakers.
- IEC 61008: Residual current operated circuit-breakers without integral overcurrent protection for household and similar uses (RCCB's)
- IEC 61009: Residual current operated circuit-breakers with integral overcurrent protection for household and similar uses (RCBO's)
- NF C 15-100: Installations électriques à basse tension.
- French decree of the 14.11.88.

Schneider Electric's Cahiers Techniques

- Earthing of the neutral in a HV industrial network, Cahier Technique no. 62, F. SAUTRIAU.
- Residual current devices, Cahier Technique no.114, R. CALVAS.
- Protections des personnes et alimentations statiques sans coupure, Cahier Technique no. 129, J.-N. FIORINA.

- Les perturbations électriques en BT, Cahier Technique no. 141, R. CALVAS.
- Introduction to dependability design, Cahier Technique no. 144, P. BONNEFOI.
- EMC: Electromagnetic compatibility, Cahier Technique no. 149, F. VAILLANT
- Overvoltages and insulation coordination in MV and HV, Cahier Technique no. 151, D. FULCHIRON
- Lightning and HV electrical installations, Cahier Technique no. 168, B. DE METZ NOBLAT
- Earthing systems worldwide and evolutions, Cahier Technique no. 173, B. LACROIX and R. CALVAS

Other publications

- Guide de l'installation électrique Ed. France Impression Conseil 1991.
- Guide de l'ingénierie électrique Ed. ELECTRA 1986.
- Electrical Review Nov. 1991 - Oct. 1992.
- La protection différentielle Cahier Technique J3E - 02/90.

Schneider Electric

Direction Scientifique et Technique,
Service Communication Technique
F-38050 Grenoble cedex 9
Télécopie : 33 (0)4 76 57 98 60
E-mail : fr-tech-com@mail.schneider.fr

DTP: HeadLines - Valence
Edition: Schneider Electric
Printing:

- 20 € -