

| 24 | 2 | Goupille élastique , 2x16 | ISO 8752 |
|-----|----|--------------------------------|--------------|
| 23 | 1 | Vis HC à bout plat, M 3-8 | ISO 4026 |
| 22 | 1 | guide de perçage | DIN 179 |
| 21 | 1 | Vis HC à bout plat, M 3-4 | ISO 4026 |
| 20 | 1 | Ressort de compression, 12,5x1 | DIN 2098 |
| 19 | 4 | ISO 1234-1.6x16-C | ISO 1234 |
| 18 | 4 | Rondelle Z, 6 | ISO 7090 |
| 17 | 1 | Vis F HC, M 6x20 | ISO 10642 |
| 16 | 2 | Ecrou hexagonal ISO 4032, M 5 | ISO 4032 |
| 15 | 2 | Rondelle Z, 5 | ISO 7090 |
| 14 | 2 | Vis C HC, M 5x30 | ISO4762 |
| 13 | 1 | poignée | X10CrNiS18-9 |
| 12 | 2 | bague intermédiaire | 9SMn28 |
| 11 | 1 | poinçon 3x17 | E335 |
| 10 | 1 | butée 5x40 | S235 |
| 9 | 2 | axe bas 6x14 | S235 |
| 8 | 1 | axe fourche 6x56 | S235 |
| 7 | 1 | axe haut 6x40 | S235 |
| 6 | 1 | fourche | S235 |
| 5 | 1 | porte poinçon | 9SMn28 |
| 4 | 2 | bras coudé | S235 |
| 3 | 1 | montant | S235 |
| 2 | 1 | support | S235 |
| 1 | 1 | corps de base | PVC |
| REP | NB | DESIGNATION | MAT / DESCR |

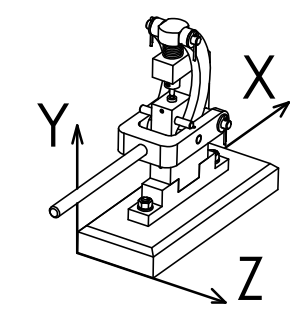

| | | | |
|---------------|------------------------|------------------------|--|
| Format : A3 | ENSEMBLE | Révisions | |
| Echelle 1 : 1 | | | |
| Dessiné par : | PRESSE A LEVIER | | |
| Le | | Construction mécanique | |