

DOCUMENTATION

Principe de la régulation MPPT.....	2
Régulateur MPPT VICTRON ENERGY BlueSolar 75 10.....	3
Batteries +12 V UNIBAT.....	4
Module de monitoring DC MARETRON DCM100.....	5
Module de monitoring et de datalogging (1/4).....	6
Module de monitoring et de datalogging (2/4).....	7
Module de monitoring et de datalogging : schéma structurel partiel (3/4).....	8
Module de monitoring et de datalogging : schéma structurel partiel (4/4).....	9
Protocole de communication VE.Direct (extrait 1/2).....	10
Protocole de communication VE.Direct (extrait 2/2).....	11
Documentation technique 6N137A (extrait 1/2).....	12
Documentation technique 6N137A (extrait 2/2).....	13
Documentation technique MC74HC1G04.....	14
La liaison S.P.I.....	15
Microcontrôleur PIC 18F26K80 (extrait 1/2).....	16
Microcontrôleur PIC 18F26K80 (extrait 2/2).....	17
Sonde tri-fonction DST800 (1/2).....	18
Sonde tri-fonction DST800 (2/2).....	19
Protocole NMEA 0183 et SHIPMODUL Miniplex-3.....	20
Le protocole NMEA 2000.....	21

SESSION 2024	BTS Systèmes Numériques Option B Électronique et Communications Épreuve E4	Page DOC1 sur 21
24SN4SNEC1	Documentation	

Principe de la régulation MPPT

Un régulateur de charge MPPT (*Maximum Power Point Tracking*) est un dispositif électronique qui permet d'obtenir le maximum de puissance électrique en sortie d'un panneau solaire, pour un ensoleillement donné. Il régule continuellement les paramètres électriques tension et courant issus du panneau solaire pour se placer au point de puissance maximale P_{max} . Ce procédé permet d'optimiser la production d'énergie pour charger la batterie et alimenter les éléments électriques connectés en sortie.

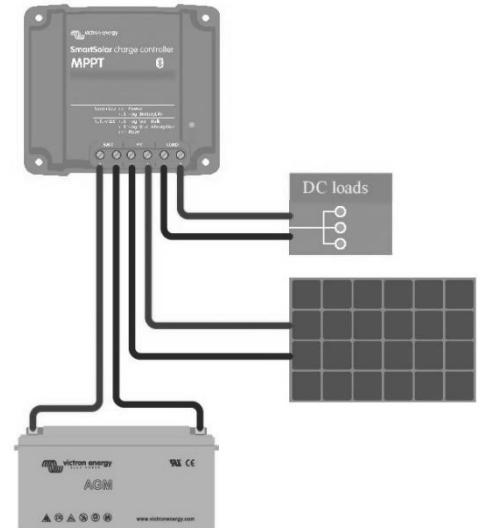

Les courbes ci-dessous présentent les caractéristiques électriques d'un panneau solaire, pour un ensoleillement donné :

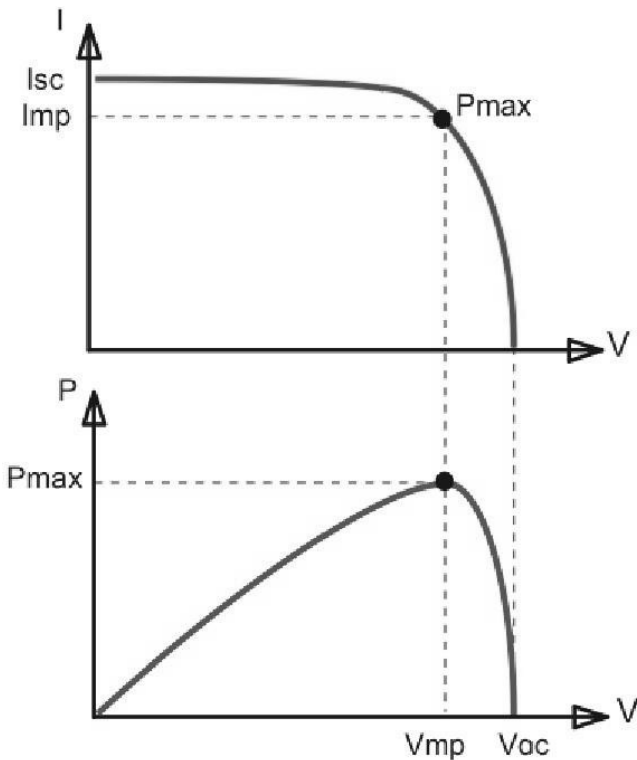

I : intensité du courant délivré par le panneau solaire

I_{sc} : intensité du courant de court-circuit

I_{mp} : intensité du courant au point de puissance maximale

V : tension délivrée par le panneau solaire

V_{oc} : tension de sortie à vide (circuit ouvert)

V_{mp} : tension au point de puissance maximale

P_{max} : point de puissance maximale

La courbe supérieure présente l'intensité du courant de sortie I délivré par le panneau solaire en fonction de la tension de sortie V . Le point de puissance maximal (MPP – *Maximum Power Point*) est le point P_{max} sur la courbe où le produit $I \times V$ est maximal.

La courbe inférieure présente la puissance de sortie P du panneau solaire en fonction de la tension de sortie V . Sans régulation MMPT, la tension du panneau solaire serait égale à la tension de la batterie, donc inférieure à V_{mp} . La puissance ne serait pas maximale et la production d'énergie non optimisée.

SESSION 2024	BTS Systèmes Numériques Option B Électronique et Communications Épreuve E4	Page DOC2 sur 21
24SN4SNEC1	Documentation	

Régulateur MPPT VICTRON ENERGY BlueSolar 75|10

10.1. Spécifications 75/10, 75/15, 100/15 et 100/20

	MPPT 75/10	MPPT 75/15	MPPT 100/15	MPPT 100/20
Tension de la batterie (sélection automatique)	12 V ou 24 V			12 V, 24 V, ou 48 V
Courant de batterie maximal	10 A	15 A	15 A	20 A
Puissance PV nominale, 12 V ^{1a,b}	145 W	220 W	220 W	290 W
Puissance PV nominale, 24 V ^{1a,b}	290 W	440 W	440 W	580 W
Puissance PV nominale, 48 V ^{1a,b}	-	-	-	1160 W
Courant de court-circuit PV max. ²	10 A	15 A	15 A	20 A
Déconnexion de charge consommatrice automatique	Oui			
Tension PV maximale de circuit ouvert	75 V		100 V	
Efficacité de crête	98 %			
Autoconsommation	12 V : 20 mA / 24 V : 10 mA			12 V : 25 mA 24 V / 48 V : 15 mA
Tension de charge « d'absorption »	14,4 V / 28,8 V / 57,6 V (réglable)			
Tension de charge « Float »	13,8 V / 27,6 V / 55,2 V (réglable)			
Tension de charge « d'égalisation » ³	16,2 V / 32,4 V / 64,8 V (réglable)			
Algorithme de charge	Algorithme adaptatif à étapes multiples ou défini par l'utilisateur			
Compensation de température	12 V : -16 mV/°C / 24 V : -32 mV/°C / 48 V : -64 mV/°C			
Communication de données	Port VE.Direct ⁴ Bluetooth, à travers l'application VictronConnect			

1a) Le chargeur solaire limitera la puissance d'entrée si davantage de puissance PV est connectée.

1b) La tension PV doit dépasser Vbat + 5 V pour que le contrôleur puisse démarrer. Ensuite, la tension PV minimale est de Vbat + 1 V.

Prix moyens constatés (T.T.C.)



SESSION 2024	BTS Systèmes Numériques Option B Électronique et Communications Épreuve E4	Page DOC3 sur 21
24SN4SNEC1	Documentation	

85,00 €

92,00 €

112,00 €

170,00€

SESSION 2024	BTS Systèmes Numériques Option B Électronique et Communications Épreuve E4	Page DOC4 sur 21
24SN4SNEC1	Documentation	



UNIBAT 80.12 GEL UNIBAT 100.12 GEL UNIBAT 150.12 GEL UNIBAT 220.12 GEL

Ref 1610 Ref 1627 Ref 1634 Ref 1641

Système

Tension batterie	12 V	12 V	12 V	12 V
Capacité nominale 20 h (C20)	80 Ah	100 Ah	150 Ah	220 Ah

Effet de la température sur la capacité

30°C : 105%
 25°C : 103%
 10°C : 95%
 -10°C : 78%

Auto décharge (25°C)

1 mois : 3%
 3 mois : 8%
 6 mois : 15%

Résistance interne (25°C)

< 5,8 mΩ < 5 mΩ < 3,1 mΩ < 2,5 mΩ

Performances

Capacité nominale	20 h (C20)	80 Ah	100 Ah	150 Ah	220 Ah
	10 h (C10)	74 Ah	95 Ah	143 Ah	200 Ah
	5 h (C5)	70 Ah	87 Ah	131 Ah	191 Ah
	1 h (C1)	56 Ah	64 Ah	99 Ah	135 Ah

DCM100

Direct Current Monitor

The DCM100 DC Monitor is an advanced electronic monitoring device used to measure the voltage and current of any direct current (DC) power source or load. Examples of DC power sources that can be monitored with the DCM100 include batteries, alternators, solar panels, and wind generators. The DCM100 can also be used to monitor DC loads like inverters, windlasses, DC refrigerators, or any DC branch circuit. When the DCM100 is used to monitor batteries, sophisticated circuitry and software algorithms monitor battery temperature, load current, charging current and terminal voltage to precisely compute battery state of charge, and time remaining. To measure current, the DCM100 uses an included state-of-the-art Hall effect current sensor which simply slips over the wire—you don't have to break connections or install connectors as you do with inline shunts used in other solutions. Best of all, the DCM100 is NMEA 2000® certified so you can view any and all DC information anywhere on the vessel using a compatible NMEA 2000 display. The DCM100 is a key component of Maretron's N2KView® vessel monitoring and control system.

Information monitored:

- Battery Voltage
- Battery Current
- Ripple Voltage
- Battery Case Temperature
- State of Charge
- Time Remaining
- Charge Efficiency Factor

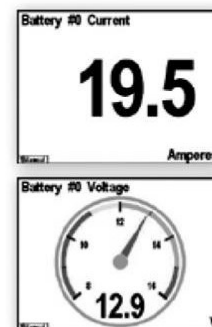

DSM Series Screen Shots

SPECIFICATIONS

PARAMETER	VALUE	COMMENT
Battery Sense Voltage Range	0 to 50 VDC	
Battery Sense Voltage Accuracy	±100 mV	
Battery Current Range	0 to 200A	With included Hall-effect current sensor
Battery Current Accuracy	±1%	With included Hall-effect current sensor

SESSION 2024	BTS Systèmes Numériques Option B Électronique et Communications Épreuve E4	Page DOC5 sur 21
24SN4SNEC1	Documentation	

Module de monitoring et de datalogging (1/4)

Afin d'analyser et d'améliorer la production d'énergie embarquée sur le voilier, un module de « *monitoring* » et de « *datalogging* » a été développé et intégré dans le sous-système de production et de gestion de l'énergie embarquée. Il collecte les données de fonctionnement issues du régulateur MPPT VICTRON ENERGY Blue Solar 75|10 par l'intermédiaire du protocole VE.Direct.



Le « *monitoring* » consiste à afficher en temps réel les données de fonctionnement de la production d'énergie sur l'afficheur MARETRON DMS410, connecté sur le réseau de communication NMEA2000 du voilier. Cette fonction peut également être réalisée sur un ordinateur à l'aide d'un logiciel émulateur de terminal.

Le « *datalogging* » consiste à enregistrer ces données sur un support de stockage numérique, de façon à pouvoir les consulter et les analyser. Pour être exploitables, ces données doivent être horodatées au format jj/mm/aaaa hh:mm:ss (jour/mois/année heure/minute/seconde).

Les données à enregistrer sont les suivantes :

- Numéro de série du régulateur MPPT
- Tension de l'assemblage de modules OPV (panneau solaire)
- Puissance fournie par l'assemblage de modules OPV
- Tension de la batterie
- Courant absorbé ou débité par la batterie
- Courant fourni en sortie du régulateur MPPT VICTRON

L'enregistrement des ces données numériques est synchronisé avec leur périodicité d'émission depuis le régulateur MPPT VICTRON.

- Diagramme de blocs internes du module :

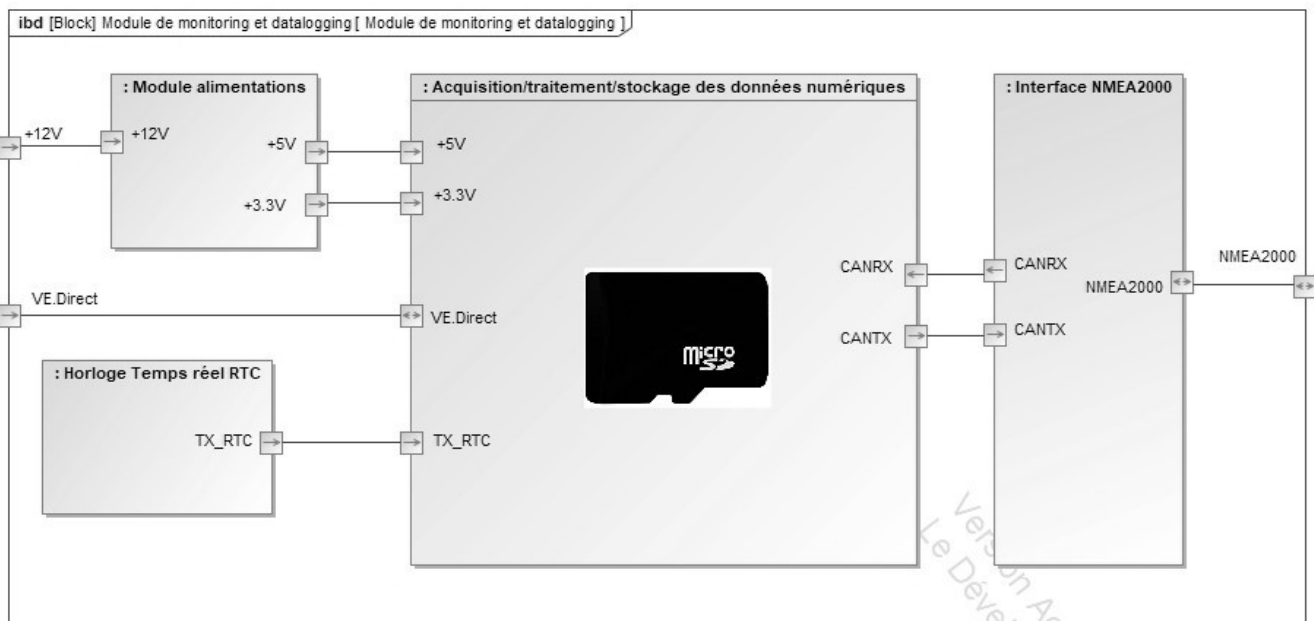

SESSION 2024	BTS Systèmes Numériques Option B Électronique et Communications Épreuve E4	Page DOC6 sur 21
24SN4SNEC1	Documentation	

Module de monitoring et de datalogging (2/4)

Diagramme des exigences :

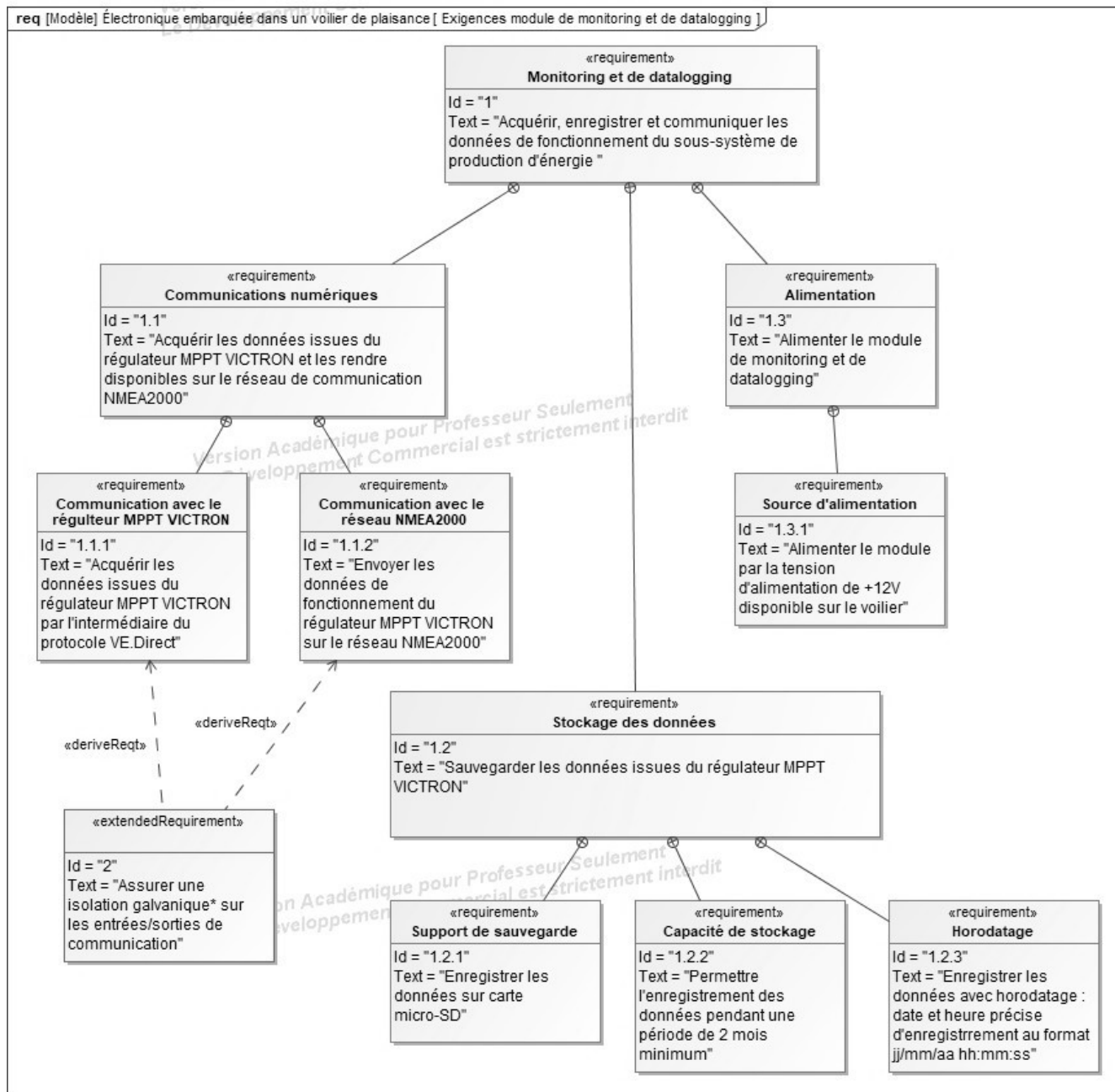

* L'isolation galvanique consiste à isoler électriquement des circuits électroniques (pas de liaisons conductrices), tout en garantissant la transmission du signal. Cela permet d'éviter de propager les anomalies électriques. L'isolation galvanique peut être magnétique (transformateur), électromécanique (relais) ou optique (optocoupleur).

SESSION 2024	BTS Systèmes Numériques Option B Électronique et Communications Épreuve E4	Page DOC7 sur 21
24SN4SNEC1	Documentation	

Module de monitoring et de datalogging : schéma structurel partiel (3/4)

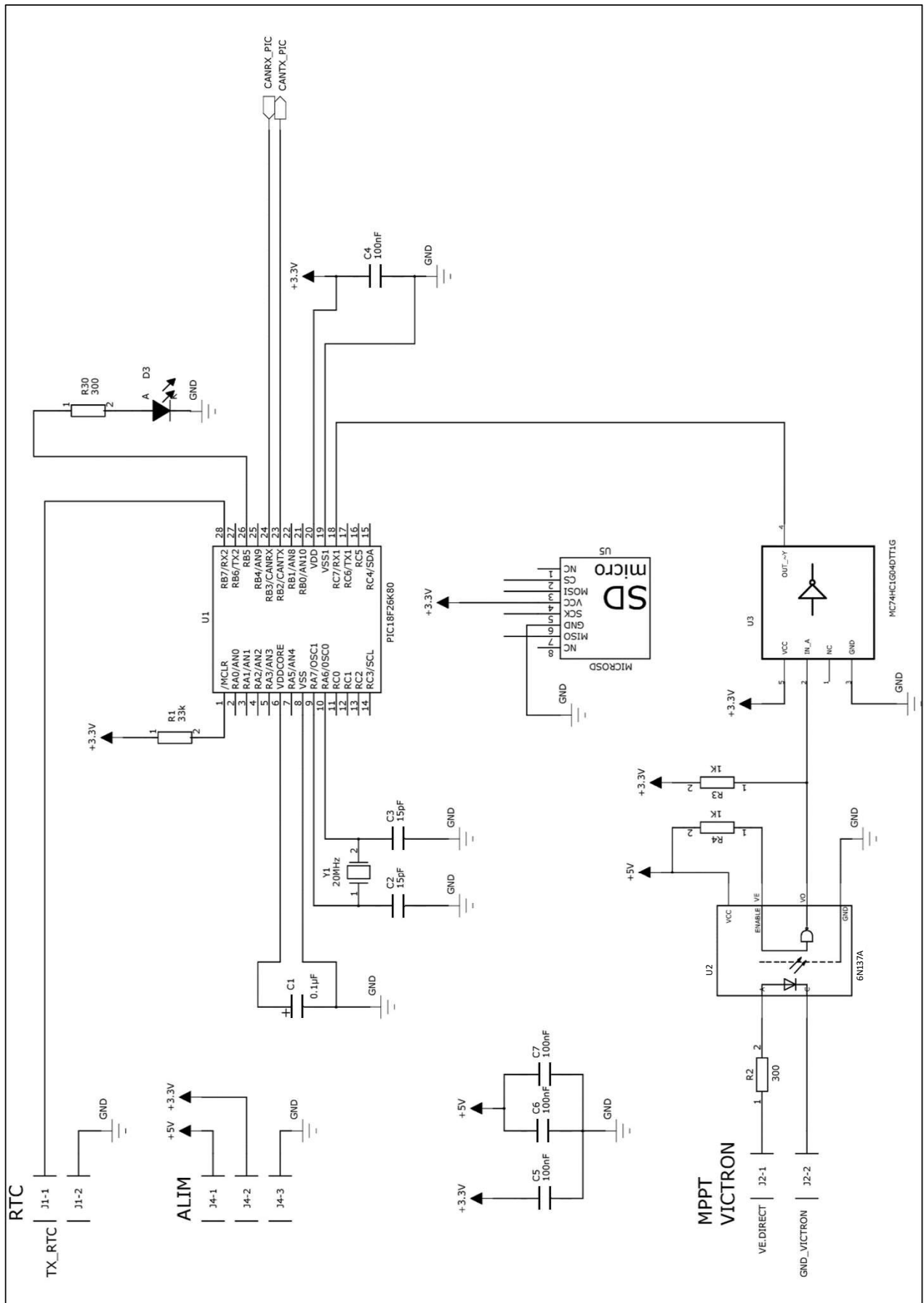

SESSION 2024	BTS Systèmes Numériques Option B Électronique et Communications Épreuve E4	Page DOC8 sur 21
24SN4SNEC1	Documentation	

Module de monitoring et de datalogging : schéma structurel partiel (4/4)

SESSION 2024	BTS Systèmes Numériques Option B Électronique et Communications Épreuve E4	Page DOC9 sur 21
24SN4SNEC1	Documentation	

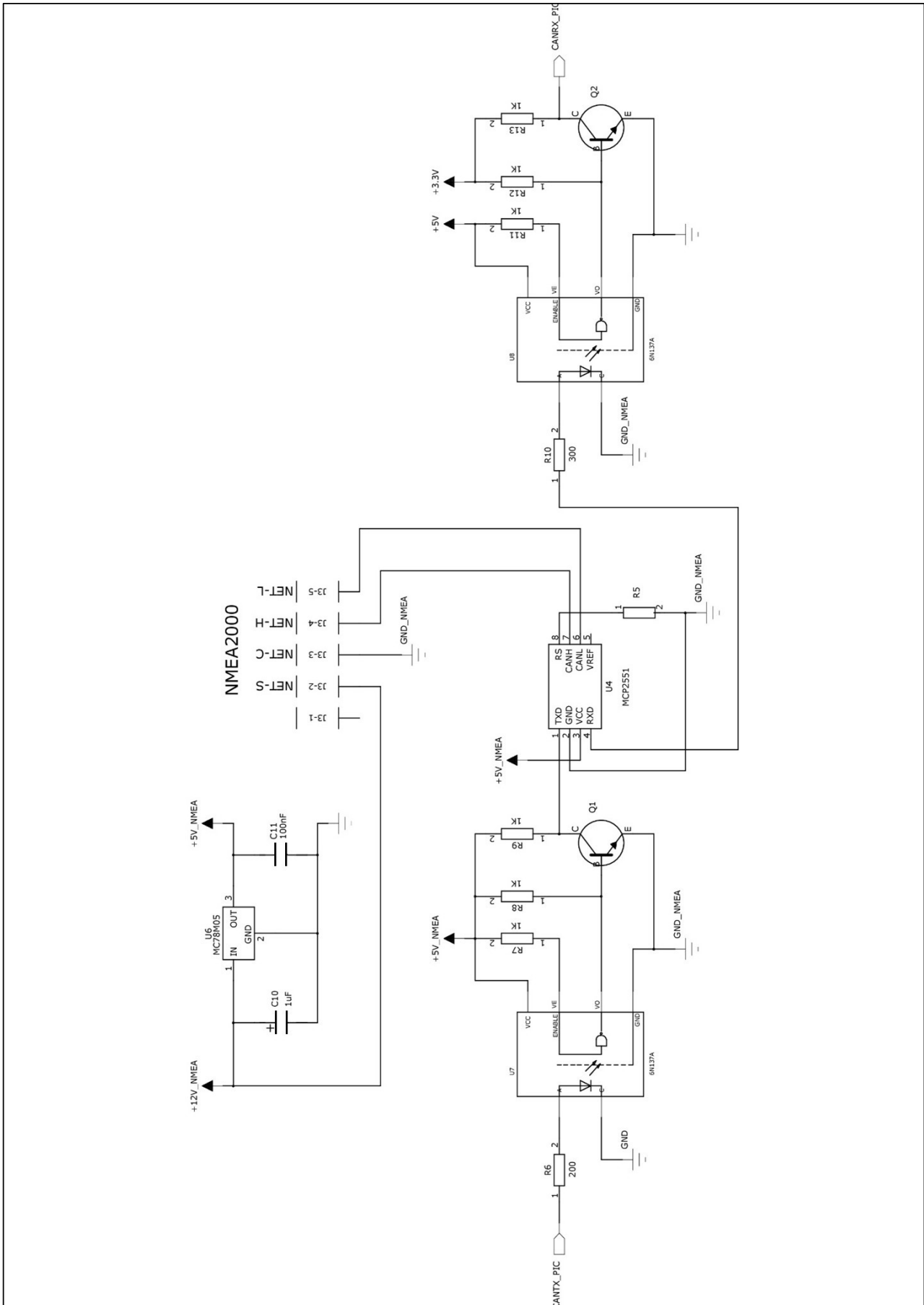

Serial port configuration

Baud rate: 19200
Data bits: 8
Parity: None
Stop bits: 1
Flow control: None

Message format

The device transmits blocks of data at 1 second intervals. Each field is sent using the following format:

<Newline><Field-Label><Tab><Field-Value>

The identifiers are defined as follows:

Identifier	Meaning
<Newline>	A carriage return followed by a line feed (0x0D, 0x0A).
<Field-Label>	An arbitrary length label that identifies the field. Where applicable, this will be the same as the label that is used on the LCD.
<Tab>	A horizontal tab (0x09).
<Field-Value>	The ASCII formatted value of this field. The number of characters transmitted depends on the magnitude and sign of the value.

Data integrity

The statistics are grouped in blocks with a checksum appended. The last field in a block will always be "Checksum". The value is a single byte, and will not necessarily be a printable ASCII character. The modulo 256 sum of all bytes in a block will equal 0 if there were no transmission errors. Multiple blocks are sent containing different fields.

SESSION 2024	BTS Systèmes Numériques Option B Électronique et Communications Épreuve E4	Page DOC11 sur 21
24SN4SNEC1	Documentation	

Protocole de communication VE.Direct (extrait 2/2)

The units used by the serial interface are as follows:

Label	Units	Description	BMV 60x	BMV 70x	BMV71x SmartShunt	MPPT ¹	Phoenix Inverter	Phoenix Charger
V	mV	Main or channel 1 (battery) voltage	*	*	*	*	*	*
V2	mV	Channel 2 (battery) voltage						* ²
V3	mV	Channel 3 (battery) voltage						* ²
VS	mV	Auxiliary (starter) voltage	* ³	* ³	* ³			
VM	mV	Mid-point voltage of the battery bank		* ⁴	* ⁴			
DM	%	Mid-point deviation of the battery bank		* ⁴	* ⁴			
VPV	mV	Panel voltage				*		
PPV	W	Panel power				*		
I	mA	Main or channel 1 battery current	*	*	*	* ⁵		*
I2	mA	Channel 2 battery current						* ²
I3	mA	Channel 3 battery current						* ²
IL	mA	Load current				* ⁶		
LOAD		Load output state (ON/OFF)				* ⁷		
T	°C ⁸	Battery temperature		* ⁹	* ⁹			
P	W	Instantaneous power		*	*			
CE	mAh ^{10,11}	Consumed Amp Hours	*	*	*			

Label	Units	Description	BMV 60x	BMV 70x	BMV71x SmartShunt	MPPT ¹	Phoenix Inverter	Phoenix Charger
H18	0.01 kWh	Amount of charged energy (BMV) / Amount of consumed energy (DC monitor)		*	*			
H19	0.01 kWh	Yield total (user resettable counter)				*		
H20	0.01 kWh	Yield today				*		
H21	W	Maximum power today				*		
H22	0.01 kWh	Yield yesterday				*		
H23	W	Maximum power yesterday				*		
ERR		Error code				*		*
CS		State of operation				*	*	*
BMV		Model description (deprecated)	*	*	*			
FW		Firmware version (16 bit)	*	*	*	*	*	
FWE		Firmware version (24 bit)						*
PID		Product ID		*	*	*	*	*
SER#		Serial number				*	*	*
HSDS		Day sequence number (0..364)				* ¹⁷		
MODE		Device mode					*	*
AC_OUT_V	0.01 V	AC output voltage					*	
AC_OUT_I	0.1 A	AC output current					*	
AC_OUT_S	VA	AC output apparent power					* ¹⁸	
WARN		Warning reason					*	
MPPT		Tracker operation mode				* ¹⁹		
MON		DC monitor mode			* ²⁰			

Table I Supported Text-mode fields

PID

The product id:

BMV-700	0x203
BMV-702	0x204
BMV-700H	0x205
BlueSolar MPPT 70 15*	0x0300*
BlueSolar MPPT 75 50*	0xA040*
BlueSolar MPPT 150 35*	0xA041*
BlueSolar MPPT 75 15	0xA042
BlueSolar MPPT 100 15	0xA043
BlueSolar MPPT 100 30*	0xA044*
BlueSolar MPPT 100 50*	0xA045*
BlueSolar MPPT 150 70	0xA046
BlueSolar MPPT 150 100	0xA047
BlueSolar MPPT 100 50 rev2	0xA049
BlueSolar MPPT 100 30 rev2	0xA04A
BlueSolar MPPT 150 35 rev2	0xA04B
BlueSolar MPPT 75 10	0xA04C
BlueSolar MPPT 150 45	0xA04D
BlueSolar MPPT 150 60	0xA04E
BlueSolar MPPT 150 85	0xA04F
SmartSolar MPPT 250 100	0xA050



High Speed Optocoupler, 10 MBd

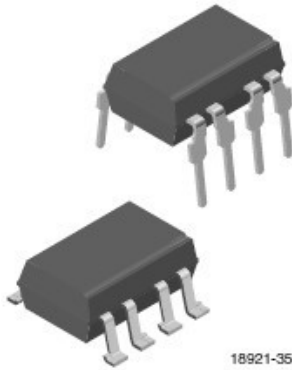

18921-35

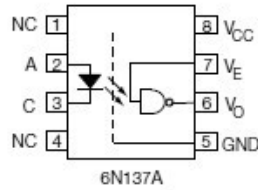

6N137A



Truth Table (Positive Logic)

LED	ENABLE	OUTPUT
ON	H	L
OFF	H	H
ON	L	H
OFF	L	H
ON	NC	L
OFF	NC	H

FEATURES

- CMR performance of 1 kV/μs
- High speed: 10 MBd typical
- LSTTL/TTL compatibility
- Low input current capability: 5 mA
- Material categorization:
For definitions of compliance please see www.vishay.com/doc?99912



RoHS COMPLIANT

APPLICATIONS

- Microprocessor system interface
- PLC, ATE input/output isolation
- Computer peripheral interface
- Digital fieldbus isolation: CC-link, DeviceNet, profibus, SDS
- High speed A/D and D/A conversion
- AC plasma display panel level shifting
- Multiplexed data transmission
- Digital control power supply
- Ground loop elimination

DESCRIPTION

The 6N137A is single channel 10 MBd optocouplers utilizing a high efficient input LED coupled to a very high speed integrated photo-detector logic gate with a strobable output. This detector features an open collector. The internal shield provides a guaranteed common mode transient immunity of 1 kV/μs. The use of a 0.1 μF bypass capacitor connected between pin 5 and 8 is recommended.

AGENCY APPROVALS

(Parts are certified under base model 6N137A)

- UL1577 file number: E52744, double protection
- cUL tested to CSA 22.2 bulletin 5A
- DIN EN 60747-5-5 (VDE 0884-5), available with option 1
- CQC GB8898, GB4943.1

RECOMMENDED OPERATING CONDITIONS

PARAMETER	TEST CONDITION	SYMBOL	MIN.	MAX.	UNIT
Operating temperature		T _{amb}	- 40	85	°C
Supply voltage		V _{CC}	4.5	5.5	V
Input current low level		I _{FL}	0	250	μA
Input current high level		I _{FH}	5	15	mA
Logic high enable voltage		V _{EH}	2	V _{CC}	V
Logic low enable voltage		V _{EL}	0	0.8	V
Output pull up resistor		R _L	330	4K	Ω
Fanout	R _L = 1 kΩ	N		5	-

SESSION 2024	BTS Systèmes Numériques Option B Électronique et Communications Épreuve E4	Page DOC12 sur 21
24SN4SNEC1	Documentation	



ELECTRICAL CHARACTERISTICS ($T_{amb} = 25\text{ }^{\circ}\text{C}$, unless otherwise specified)						
PARAMETER	TEST CONDITION	SYMBOL	MIN.	TYP.	MAX.	UNIT
INPUT						
Input forward voltage	$I_F = 10\text{ mA}$	V_F		1.35	1.7	V
Input forward voltage temperature coefficient	$I_F = 10\text{ mA}$	$\Delta V_F/\Delta T$		- 1.2		mV/K
Input reverse voltage	$I_R = 10\text{ }\mu\text{A}$	BV_R	5			V
Input threshold current	$V_E = 2\text{ V}$, $V_{CC} = 5.5\text{ V}$, $I_{OL}(\text{sinking}) = 13\text{ mA}$	I_{TH}		1.8	5	mA
Input capacitance	$f = 1\text{ MHz}$, $V_F = 0\text{ V}$	C_I		28		pF
OUTPUT						
High level supply current	$V_E = 0.5\text{ V}$, $I_F = 0\text{ mA}$	I_{OCH}		8	10	mA
	$V_E = V_{CC}$, $I_F = 10\text{ mA}$			5.8		
Low level supply current	$V_E = 0.5\text{ V}$, $I_F = 0\text{ mA}$	I_{OCL}		10	13	mA
	$V_E = V_{CC}$, $I_F = 10\text{ mA}$			8		
High level enable current	$V_E = 2\text{ V}$	I_{EH}		- 0.6	- 1.6	mA
Low level enable current	$V_E = 0.5\text{ V}$	I_{EL}		- 0.9	- 1.6	mA
High level enable voltage		V_{EH}	2			V
Low level enable voltage		V_{EL}			0.8	V
High level output current	$V_E = 2\text{ V}$, $V_{CC} = 5.5\text{ V}$, $V_O = 5.5\text{ V}$, $I_F = 250\text{ }\mu\text{A}$	I_{OH}		0.02	100	μA
Low level output voltage	$V_E = 2\text{ V}$, $V_{CC} = 5.5\text{ V}$, $I_F = 5\text{ mA}$, $I_{OL}(\text{sinking}) = 13\text{ mA}$	V_{OL}		0.13	0.60	V
Collector emitter capacitance	$f = 1\text{ MHz}$, $T_{amb} = 25\text{ }^{\circ}\text{C}$	C_{IO}		4		pF
COUPLER						
Coupling capacitance	$f = 1\text{ MHz}$, $T_{amb} = 25\text{ }^{\circ}\text{C}$	C_{IO}		0.9		pF

Note

- Minimum and maximum values are testing requirements. Typical values are characteristics of the device and are the result of engineering evaluation. Typical values are for information only and are not part of the testing requirements.

SWITCHING CHARACTERISTICS						
PARAMETER	TEST CONDITION	SYMBOL	MIN.	TYP.	MAX.	UNIT
Propagation delay time to high output level	$R_L = 350\text{ }\Omega$, $C_L = 15\text{ pF}$	t_{PLH}	25	45	75 ⁽¹⁾	ns
Propagation delay time to low output level	$R_L = 350\text{ }\Omega$, $C_L = 15\text{ pF}$	t_{PHL}	25	32	75 ⁽¹⁾	ns
Pulse width distortion	$R_L = 350\text{ }\Omega$, $C_L = 15\text{ pF}$	$ t_{PHL} - t_{PLH} $		13	35	ns
Propagation delay skew	$R_L = 350\text{ }\Omega$, $C_L = 15\text{ pF}$	t_{PSK}		16	40	ns
Output rise time (10 % to 90 %)	$R_L = 350\text{ }\Omega$, $C_L = 15\text{ pF}$	t_r		27		ns
Output fall time (90 % to 10 %)	$R_L = 350\text{ }\Omega$, $C_L = 15\text{ pF}$	t_f		10		ns
Propagation delay time of enable from V_{EH} to V_{EL}	$R_L = 350\text{ }\Omega$, $C_L = 15\text{ pF}$, $V_{EL} = 0\text{ V}$, $V_{EH} = 3\text{ V}$	t_{ELH}		47		ns
Propagation delay time of enable from V_{EL} to V_{EH}	$R_L = 350\text{ }\Omega$, $C_L = 15\text{ pF}$, $V_{EL} = 0\text{ V}$, $V_{EH} = 3\text{ V}$	t_{EHL}		24		ns

Notes

- Over recommended temperature ($T_{amb} = -40\text{ }^{\circ}\text{C}$ to $+85\text{ }^{\circ}\text{C}$), $V_{CC} = 5\text{ V}$, $I_F = 7.5\text{ mA}$, unless otherwise specified. Typical values applies to $V_{CC} = 5\text{ V}$, $T_{amb} = 25\text{ }^{\circ}\text{C}$

⁽¹⁾ A JEDEC registered data for 6N137A

SESSION 2024	BTS Systèmes Numériques Option B Électronique et Communications Épreuve E4	Page DOC13 sur 21
24SN4SNEC1	Documentation	

MC74HC1G04

Single Inverter

The MC74HC1G04 is a high speed CMOS inverter fabricated with silicon gate CMOS technology.

The internal circuit is composed of multiple stages, including a buffer output which provides high noise immunity and stable output.

The MC74HC1G04 output drive current is 1/2 compared to MC74HC series.

- High Speed: $t_{PD} = 7 \text{ ns}$ (Typ) at $V_{CC} = 5 \text{ V}$
- Low Power Dissipation: $I_{CC} = 1 \mu\text{A}$ (Max) at $T_A = 25^\circ\text{C}$
- High Noise Immunity
- Balanced Propagation Delays ($t_{pLH} = t_{pHL}$)
- Symmetrical Output Impedance ($I_{OH} = I_{OL} = 2 \text{ mA}$)
- Chip Complexity: FET = 105
- NLV Prefix for Automotive and Other Applications Requiring Unique Site and Control Change Requirements; AEC-Q100 Qualified and PPAP Capable
- These Devices are Pb-Free and are RoHS Compliant

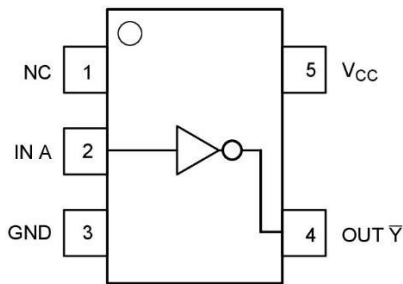

Figure 1. Pinout (Top View)

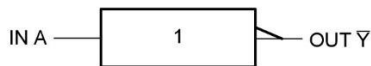

Figure 2. Logic Symbol



ON Semiconductor®

<http://onsemi.com>



SC-88A
(SC70-5/SOT-353)
DF SUFFIX
CASE 419A

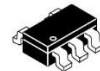

TSOP-5
DT SUFFIX
CASE 483

MARKING DIAGRAMS

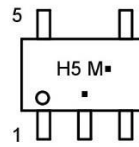

SC-88A

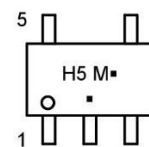

TSOP-5

- H5 = Specific Device Code
- M = Date Code
- = Pb-Free Package

(Note: Microdot may be in either location)

PIN ASSIGNMENT	
1	NC
2	IN A
3	GND
4	OUT \bar{Y}
5	V_{CC}

FUNCTION TABLE

Input A	Output \bar{Y}
L	H
H	L

ORDERING INFORMATION

See detailed ordering and shipping information in the package dimensions section on page 4 of this data sheet.

SESSION 2024	BTS Systèmes Numériques Option B Électronique et Communications Épreuve E4	Page DOC14 sur 21
24SN4SNEC1	Documentation	

La liaison S.P.I.

Une liaison SPI (pour *Serial Peripheral Interface*) est un bus de données série synchrone baptisé ainsi par Motorola, au milieu des années 1980, qui opère en mode full-duplex. Les circuits communiquent selon un schéma maître-esclave, où le maître contrôle la communication. Plusieurs esclaves peuvent coexister sur un même bus, dans ce cas, la sélection du destinataire se fait par une ligne dédiée entre le maître et l'esclave appelée « Slave Select (SS) ».

Le bus SPI utilise quatre signaux logiques :

- SCLK : Serial Clock, Horloge (généralisé par le maître)
- MOSI : Master Output, Slave Input (généralisé par le maître)
- MISO : Master Input, Slave Output (généralisé par l'esclave)
- SS : Slave Select, Actif à l'état bas (généralisé par le maître)

Il existe d'autres noms qui sont souvent utilisés :

- SCK, SCL : Horloge (généralisé par le maître)
- SDI, DI, SI : Serial Data IN, MISO
- SDO, SDA, DO, SO : Serial Data OUT, MOSI
- nCS, CS, nSS, STE, CSN — SS

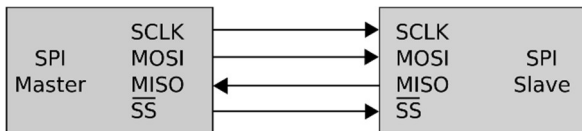

Liaison SPI : un maître et un esclave

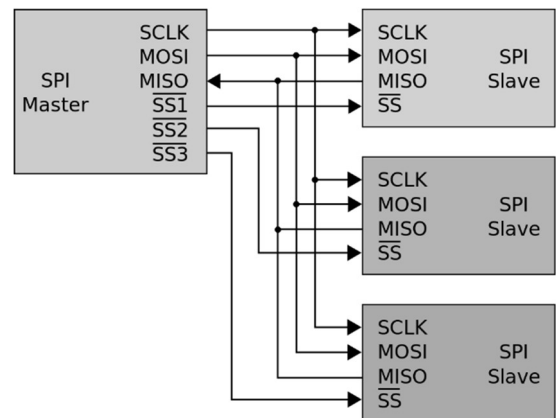

Liaison SPI avec un maître et trois esclaves

Une transmission SPI typique est une communication simultanée entre un maître et un esclave. Le maître génère l'horloge et sélectionne l'esclave avec qui il veut communiquer par l'utilisation du signal SS. À chaque coup d'horloge le maître et l'esclave s'échangent un bit. Après huit coups d'horloges le maître a transmis un octet à l'esclave et vice versa. La vitesse de l'horloge est réglée selon des caractéristiques propres aux périphériques.

- Exemple d'un échange SPI entre un circuit maître et un circuit esclave :

SESSION 2024	BTS Systèmes Numériques Option B Électronique et Communications Épreuve E4	Page DOC15 sur 21
24SN4SNEC1	Documentation	

Documentation technique MC74HC1G04

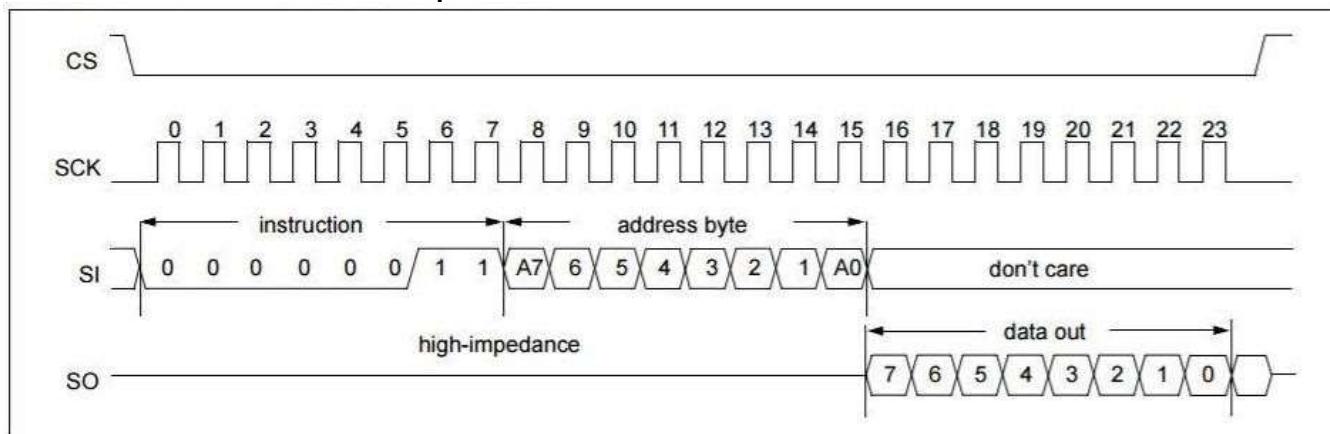

SESSION 2024	BTS Systèmes Numériques Option B Électronique et Communications Épreuve E4	Page DOC16 sur 21
24SN4SNEC1	Documentation	



PIC18F66K80 FAMILY

28/40/44/64-Pin, Enhanced Flash Microcontrollers with ECAN™ and nanoWatt XLP Technology

Power-Managed Modes:

- Run: CPU on, Peripherals on
- Idle: CPU off, Peripherals on
- Sleep: CPU off, Peripherals off
- Two-Speed Oscillator Start-up
- Fail-Safe Clock Monitor (FSCM)
- Power-Saving Peripheral Module Disable (PMD)
- Ultra Low-Power Wake-up
- Fast Wake-up, 1 μ s, Typical
- Low-Power WDT, 300 nA, Typical
- Run mode Currents Down to Very Low 3.8 μ A, Typical
- Idle mode Currents Down to Very Low 880 nA, Typical
- Sleep mode Current Down to Very Low 13 nA, Typical

ECAN Bus Module Features:

- Conforms to CAN 2.0B Active Specification
- Three Operating modes:
 - Legacy mode (full backward compatibility with existing PIC18CXX8/FXX8 CAN modules)
 - Enhanced mode
 - FIFO mode or programmable TX/RX buffers
- Message Bit Rates up to 1 Mbps
- DeviceNet™ Data Byte Filter Support
- Six Programmable Receive/Transmit Buffers
- Three Dedicated Transmit Buffers with Prioritization
- Two Dedicated Receive Buffers

ECAN Bus Module Features (Continued):

- 16 Full, 29-Bit Acceptance Filters with Dynamic Association
- Three Full, 29-Bit Acceptance Masks
- Automatic Remote Frame Handling
- Advanced Error Management Features

Special Microcontroller Features:

- Operating Voltage Range: 1.8V to 5.5V
- On-Chip 3.3V Regulator
- Operating Speed up to 64 MHz
- Up to 64 Kbytes On-Chip Flash Program Memory:
 - 10,000 erase/write cycle, typical
 - 20 years minimum retention, typical
- 1,024 Bytes of Data EEPROM:
 - 100,000 Erase/write cycle data EEPROM memory, typical
- 3.6 Kbytes of General Purpose Registers (SRAM)
- Three Internal Oscillators: LF-INTOSC (31 KHz), MF-INTOSC (500 kHz) and HF-INTOSC (16 MHz)
- Self-Programmable under Software Control
- Priority Levels for Interrupts
- 8 x 8 Single-Cycle Hardware Multiplier
- Extended Watchdog Timer (WDT):
 - Programmable period from 4 ms to 4,194s
- In-Circuit Serial Programming™ (ICSP™) via Two Pins
- In-Circuit Debug via Two Pins
- Programmable BOR
- Programmable LVD

TABLE 1: DEVICE COMPARISON

Device	Program Memory	Data Memory (Bytes)	Data EE (Bytes)	Pins	I/O	CTMU	12-Bit A/D Channels	CCP/ ECCP	Timers 8-Bit/16-Bit	EUSART	Comparators	ECAN™	MSSP	BORMV/LVD	DSM
PIC18F25K80	32 Kbytes	3,648	1,024	28	24	1	8-ch	4/1	2/3	2	2	1	1	Yes	No
PIC18LF25K80	32 Kbytes	3,648	1,024	28	24	1	8-ch	4/1	2/3	2	2	1	1	Yes	No
PIC18F26K80	64 Kbytes	3,648	1,024	28	24	1	8-ch	4/1	2/3	2	2	1	1	Yes	No
PIC18LF26K80	64 Kbytes	3,648	1,024	28	24	1	8-ch	4/1	2/3	2	2	1	1	Yes	No
PIC18F45K80	32 Kbytes	3,648	1,024	40/44	35	1	11-ch	4/1	2/3	2	2	1	1	Yes	No
PIC18LF45K80	32 Kbytes	3,648	1,024	40/44	35	1	11-ch	4/1	2/3	2	2	1	1	Yes	No
PIC18F46K80	64 Kbytes	3,648	1,024	40/44	35	1	11-ch	4/1	2/3	2	2	1	1	Yes	No
PIC18LF46K80	64 Kbytes	3,648	1,024	40/44	35	1	11-ch	4/1	2/3	2	2	1	1	Yes	No
PIC18F65K80	32 Kbytes	3,648	1,024	64	54	1	11-ch	4/1	2/3	2	2	1	1	Yes	Yes
PIC18LF65K80	32 Kbytes	3,648	1,024	64	54	1	11-ch	4/1	2/3	2	2	1	1	Yes	Yes
PIC18F66K80	64 Kbytes	3,648	1,024	64	54	1	11-ch	4/1	2/3	2	2	1	1	Yes	Yes
PIC18LF66K80	64 Kbytes	3,648	1,024	64	54	1	11-ch	4/1	2/3	2	2	1	1	Yes	Yes

PIC18F66K80 FAMILY

21.0 MASTER SYNCHRONOUS SERIAL PORT (MSSP) MODULE

21.1 Master SSP (MSSP) Module Overview

The Master Synchronous Serial Port (MSSP) module is a serial interface, useful for communicating with other peripheral or microcontroller devices. These peripheral devices may be devices such as serial EEPROMs, shift registers, display drivers and A/D Converters. The MSSP module can operate in either of two modes:

- Serial Peripheral Interface (SPI)
- Inter-Integrated Circuit (I²C™)
 - Full Master mode
 - Slave mode (with general address call)

The I²C interface supports the following modes in hardware:

- Master mode
- Multi-Master mode
- Slave mode with 5-bit and 7-bit address masking (with address masking for both 10-bit and 7-bit addressing)

21.2 Control Registers

The MSSP module has three associated control registers. These include a status register (SSPSTAT) and two control registers (SSPCON1 and SSPCON2). The use of these registers and their individual configuration bits differ significantly depending on whether the MSSP module is operated in SPI or I²C mode.

Additional details are provided under the individual sections.

21.3 SPI Mode

The SPI mode allows 8 bits of data to be synchronously transmitted and received simultaneously. All four modes of SPI are supported. To accomplish communication, typically three pins are used:

- Serial Data Out (SDO) – RC5/SDO
- Serial Data In (SDI) – RC4/SDA/SDI
- Serial Clock (SCK) – RC3/REF0/SCL/SCK

Additionally, a fourth pin may be used when in a Slave mode of operation:

- Slave Select (\overline{SS}) – RA5/AN4/C2INB/HLVDIN/T1CKI/ \overline{SS} /CTMU1

Figure 21-1 shows the block diagram of the MSSP module when operating in SPI mode.

FIGURE 21-1: MSSP BLOCK DIAGRAM (SPI MODE)

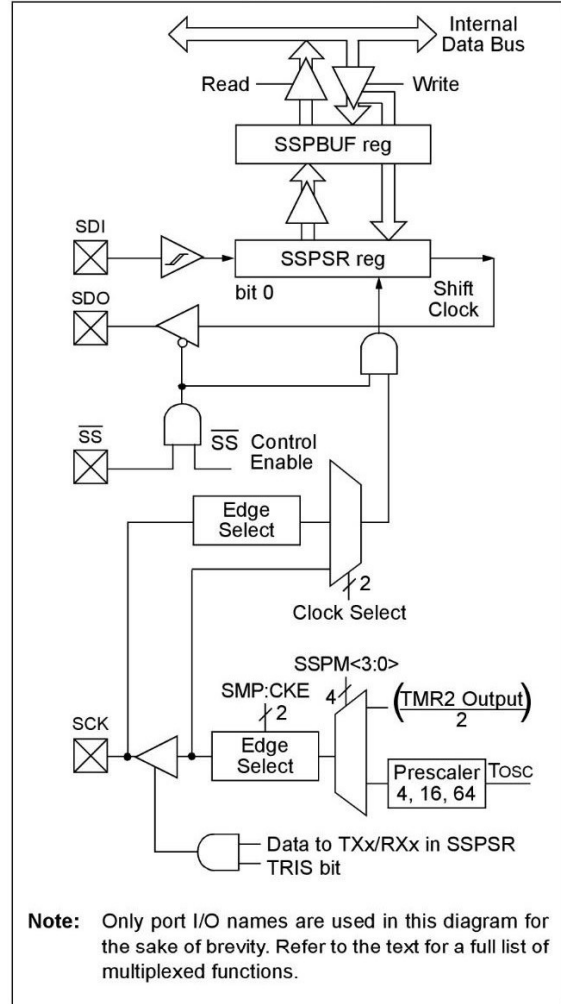

DST800

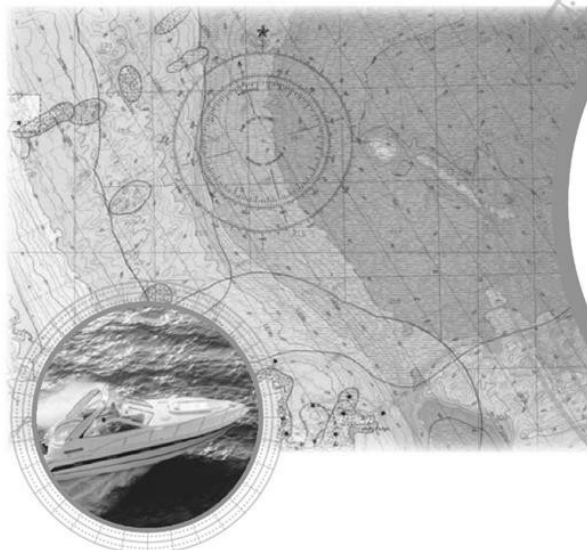

The Smart Alternative!

Airmar's DST800 Smart™ Sensor features embedded micro-electronics. Depth, speed, and temperature signals are processed inside the sensor and can be displayed on any radar, chart plotter, or device that accepts NMEA 0183 or NMEA 2000® data. The 235 kHz frequency prevents mutual interference with other echosounders on the vessel.

Single Choice for Depth, Speed, and Temperature!

The DST800 is the market's first Retractable TRIDUCER® Multisensor offering depth, speed, and temperature in a single, 51 mm (2") fitting. Only one hole through the hull simplifies the installation—an attractive feature for boat builders and boat owners alike.

Three-In-One

Patented, speed-signal-processing enhancements provide excellent paddlewheel accuracy below 5 knots (6 MPH) and smooth linear output at all vessel speeds. The transducer's wide, fan-shaped, port-starboard beam is able to find bottom even when installed on steep deadrise hulls or heeling sailboats. You also get true water-temperature readings with the DST800's reliable temperature sensor.

Valve Closes the Gap!

Airmar's innovative housing design incorporates the popular self-closing valve. When a transducer insert is removed, the valve minimizes water flow into the boat.

Thru-Hull TRIDUCER® Multisensor Smart™ Sensor

Features

- The all-in-one Smart Sensor
- Depth, speed, and temperature in one compact housing
- Available in NMEA 0183 and NMEA 2000® versions
- 235 kHz frequency prevents mutual interference with other echosounders on the vessel
- Plastic, bronze, or stainless steel housings available
- Fast-response temperature sensor provides $\pm 0.2^{\circ}\text{C}$ ($\pm 0.1^{\circ}\text{F}$) accuracy
- Available as a Smart Sensor at 235 kHz or an analog output sensor operating at either 200 kHz or 235 kHz
- Available in low-profile, countersunk, or beveled-edge housings



www.airmar.com

SESSION 2024	BTS Systèmes Numériques Option B Électronique et Communications Épreuve E4	Page DOC18 sur 21
24SN4SNEC1	Documentation	

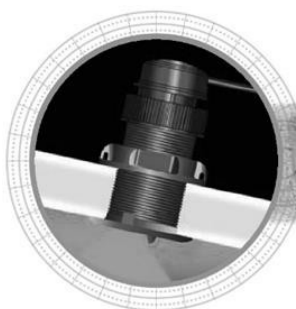

DST800

Technical Information

235 kHz-F NMEA 0183 / NMEA 2000®	
Number of Elements and Configuration	<input type="checkbox"/>
Beamwidth (@-3 dB)	10° x 44°
RMS Power (W)	60 W 100 W

SPECIFICATIONS	
Weight:	
—0.9 kg (2.0 lb)—Plastic	
—1.6 kg (3.5 lb)—Bronze	
—1.9 kg (4.2 lb)—Stainless Steel	
Acoustic Window: Urethane	
Hull Deadrise: Up to 22°	
Data Update Rate: 1 per second	
Minimum Depth Range: 0.5 m (1.6')	
Maximum Depth Range:	
—Up to 70 m (230')—NMEA 0183	
—Up to 100 m (330')—NMEA 2000	
Pressure Rating: 3 m (10')	
Pulse Rate: 20,000 p/nm* (5.6 Hz per knot)—*p/nm = pulses per nautical mile	
Supply Voltage:	
—10 VDC to 25 VDC—NMEA 0183	
—9 VDC to 16 VDC—NMEA 2000	
Supply Current:	
—<40 mA—NMEA 0183	
—<200 mA—NMEA 2000	
Standard Cable Length:	
—10 m (33')—NMEA 0183	
—6 m (20') devicenet—NMEA 2000	
Temperature Sensor Accuracy: ±0.5°C (±1.8°F)	
Temperature Sensor Range: -10°C to 40°C (14°F to 104°F)	
NMEA 2000® Load Equivalency Number (LEN): 4	
CE Regulation: Complies to IERC60945	

DATA OUTPUT PROTOCOL	
NMEA 0183 Sentence Structure	
\$SDBT, DDPT...	Depth
\$VWVHW	Speed
\$VWVLW	Distance
\$YXMTW	Water Temperature
NMEA 2000® Supported PGNs	
59392	ISO Acknowledgement
600928	ISO Address Claim
126208	Acknowledge Group Function
126464	Transmit PGN List Group Function
126464	Received PGN List Group Function
126996	Product Information
128259	Speed (Speed Water Reference)
128267	Water Depth (With Transducer Offset)
128275	Distance Log
130310	Environmental Parameters (Water Temperature)
130311	Environmental Parameters (Water Temperature)
130312	Environmental Parameters (Water Temperature)

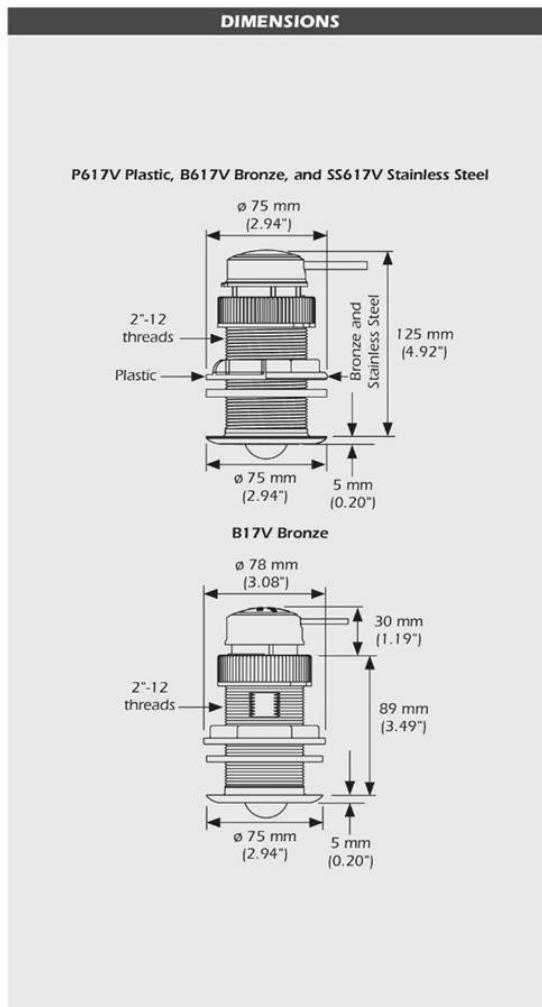

©Airmar Technology Corporation

DST800_rP 02/14/20

As Airmar constantly improves its products, all specifications are subject to change without notice. All Airmar products are designed to provide high levels of accuracy and reliability, however they should only be used as aids to navigation and not as a replacement for traditional navigation aids and techniques. Smart™ and TRIDUCER® are trademarks and registered trademarks of Airmar Technology Corporation. Other company or product names mentioned in this document may be trademarks or registered trademarks of their respective companies, which are not affiliated with Airmar.

SESSION 2024	BTS Systèmes Numériques Option B Électronique et Communications Épreuve E4	Page DOC19 sur 21
24SN4SNEC1	Documentation	

Protocole NMEA 0183 et SHIPMODUL Miniplex-3

Protocole NMEA 0183

La norme 0183 utilise une simple communication série reposant sur le protocole RS422 pour transmettre des données à un ou plusieurs écoutants. Une trame NMEA 0183 utilise tous les caractères ASCII.

Exemple pour un message de profondeur d'eau :

```
$SDDBT,112.2,f,34.2,M,18.7,F*0D<CR><LF>
```

1 pied (feet) = 0,3048 m

1 brasse (fathom) = 1,8288 m

DBT - Depth below transducer

```
      1   2 3   4 5   6 7  
      |   | |   | |   | |  
$--DBT,x.x,f,x.x,M,x.x,F*hh<CR><LF>
```

Field Number:

1. Water depth, feet
2. f = feet
3. Water depth, meters
4. M = meters
5. Water depth, Fathoms
6. F = Fathoms
7. Checksum

SHIPMODUL Miniplex-3 Series

The MiniPlex-3 Series NMEA multiplexers comprises a range of advanced [NMEA multiplexers](#) which combines data from multiple navigation instruments.

Through an advanced filtering and routing system, this data can be sent to other navigation instruments and to computers, tablets and smartphones.

A bi-directional SeaTalk1 interface enables conversion between SeaTalk1 data and NMEA 0183 sentences. This conversion works both ways, allowing the MiniPlex-3 to replace Raymarine's SeaTalk-NMEA bridge (E85001).

MiniPlex-3 models with an NMEA 2000 interface (-N2K suffix) connect directly to an NMEA 2000 backbone and convert between NMEA 2000 PGN's, NMEA 0183 sentences and SeaTalk1 datagrams in all directions.

All data is available on one or more computer interfaces in NMEA 0183 format. NMEA 2000 PGN's and SeaTalk datagrams for which no NMEA 0183 equivalent exists, can be converted to special NMEA 0183 sentences, allowing software developers to support processing of raw NMEA 2000 and SeaTalk data.

Each and every port on a MiniPlex-3 multiplexer is galvanically isolated from the internal electronics and from every other port. This guarantees that no ground loops will be created when adding a MiniPlex-3 to a navigation network. It also ensures a trouble free connection to any type of NMEA 0183 port of any device.

The MiniPlex-3 multiplexers are all functionally identical but differ in type and number of computer interfaces.



SESSION 2024	BTS Systèmes Numériques Option B Électronique et Communications Épreuve E4	Page DOC20 sur 21
24SN4SNEC1	Documentation	

PGN: 127508 - Battery Status

Field #1: Battery Instance
Bits: 8
Signed: false

Field #2: Voltage
Bits: 16
Units: V
Resolution: 0.01
Signed: false

Field #3: Current
Bits: 16
Units: A
Resolution: 0.1
Signed: true

Field #4: Temperature
Bits: 16
Units: K
Type: Temperature
Resolution: 0.01
Signed: false

Field #5: SID
Bits: 8
Signed: false

PGN: 128259 - Speed

Field #1: SID
Bits: 8
Signed: false

Field #2: Speed Water Referenced
Bits: 16
Units: m/s
Resolution: 0.01
Signed: false

Field #3: Speed Ground Referenced
Bits: 16
Units: m/s
Resolution: 0.01
Signed: false

Field #4: Speed Water Referenced Type
Bits: 4
Type: Lookup table
Signed: false

PGN: 128267 - Water Depth

Field #1: SID
Bits: 8
Signed: false

Field #2: Depth - Depth below transducer
Bits: 32
Units: m
Resolution: 0.01
Signed: false

Field #3: Offset - Distance between transducer and surface (positive) or keel (negative)
Bits: 16
Units: m
Resolution: 0.001
Signed: true

Field #4: Unused (0xFF)

SESSION 2024	BTS Systèmes Numériques Option B Électronique et Communications Épreuve E4	Page DOC22 sur 21
24SN4SNEC1	Documentation	