



Ne rien écrire dans la partie barrée

S022-DR/2024-04-02 12:00:14

Questions 21 et 22

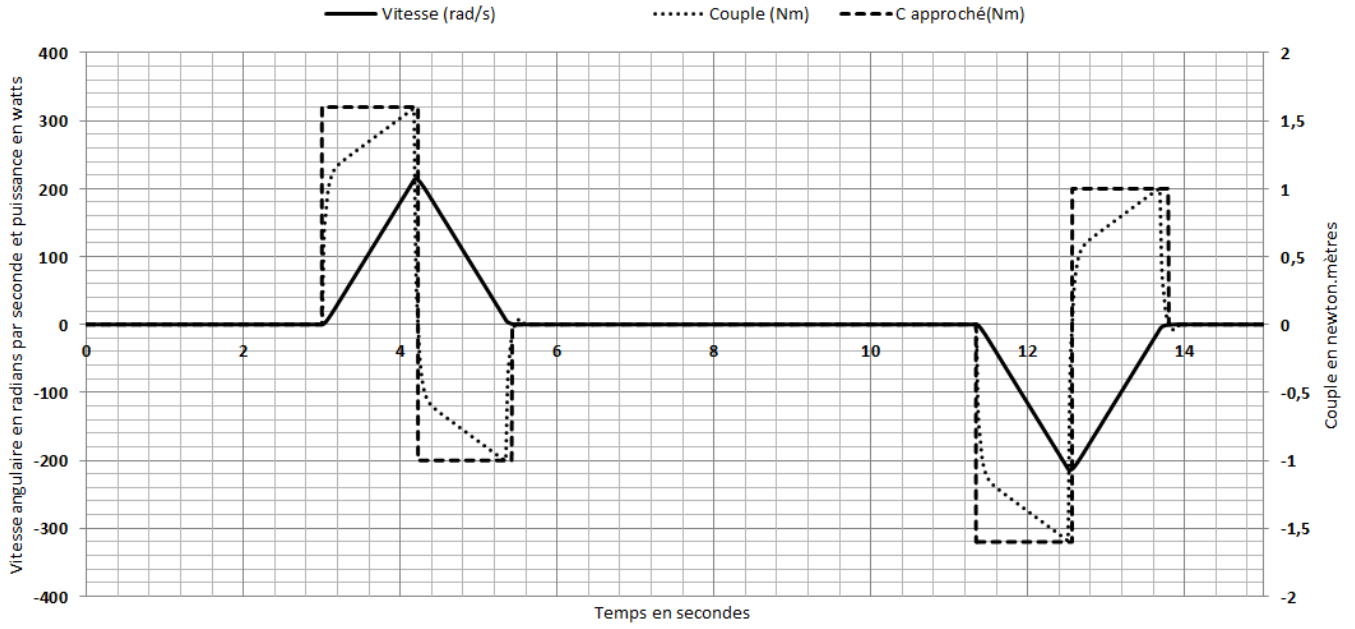

Figure B

Question 29

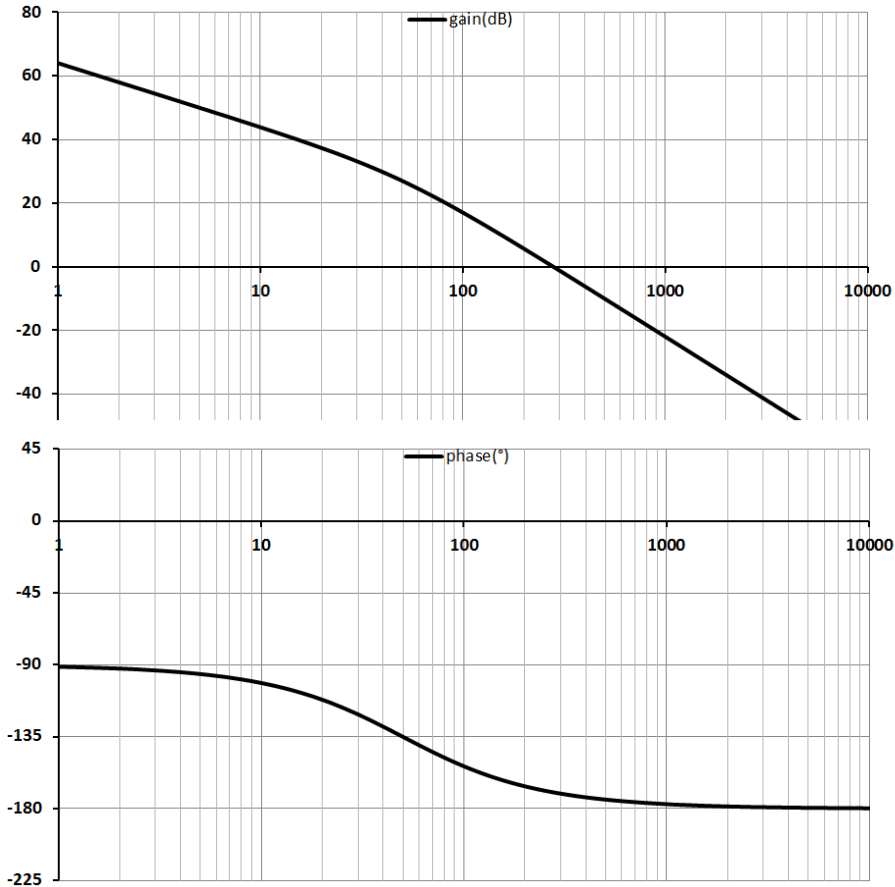

Figure C



### Question 35

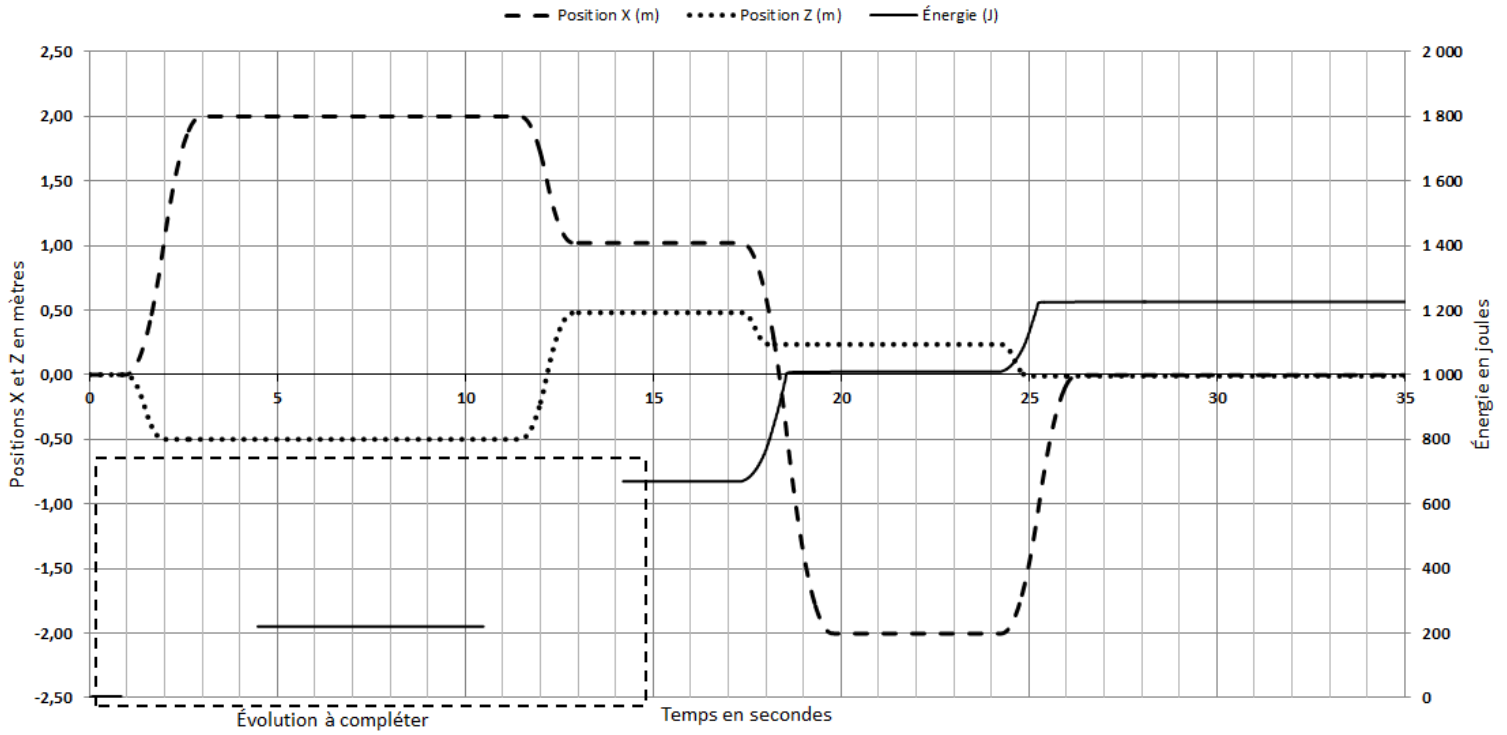

Figure E

### Question 39

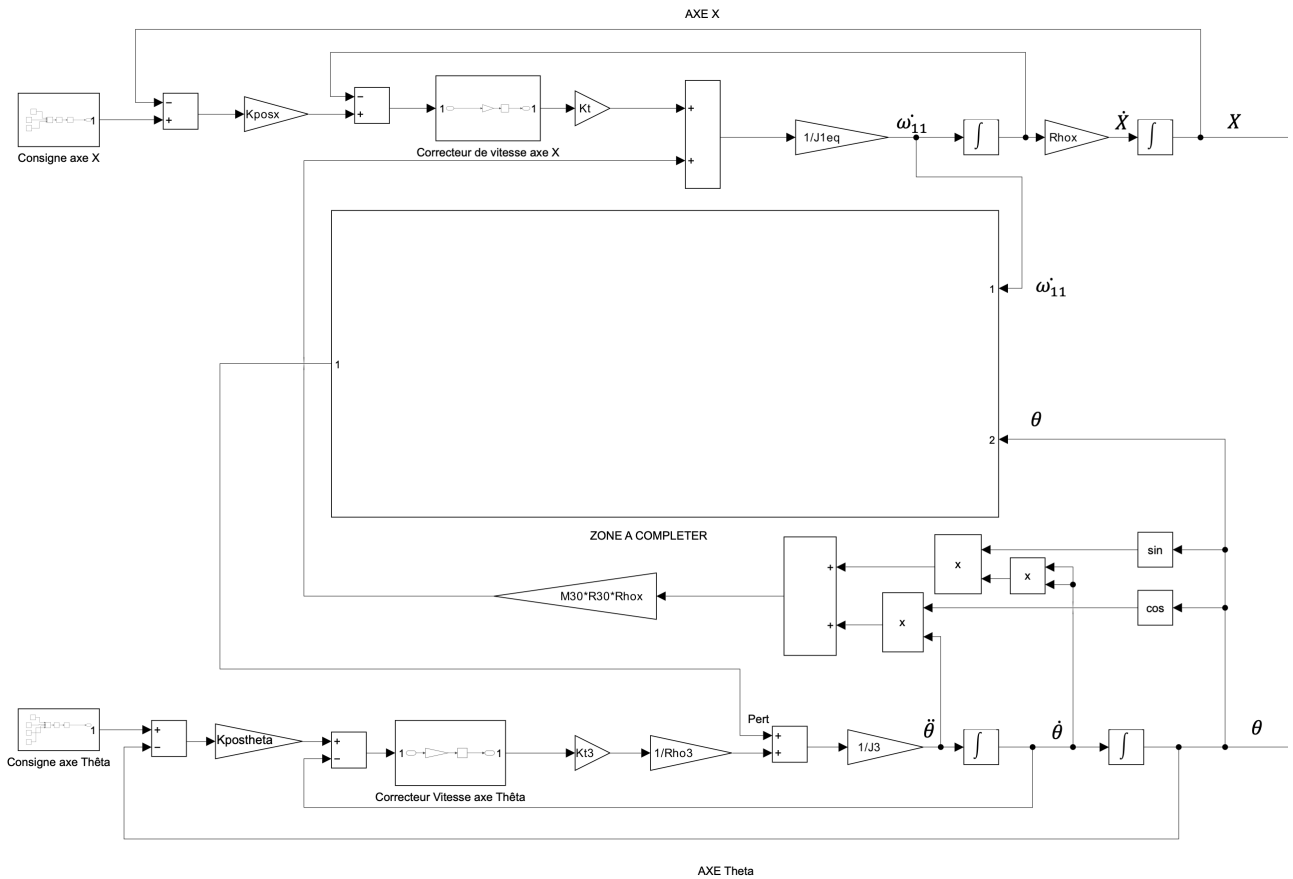

Figure F